

DATA SHEET



SAA4979H

Sample rate converter with
embedded high quality dynamic
noise reduction and expansion port

Product specification

2002 May 28

Sample rate converter with embedded high quality dynamic noise reduction and expansion port

SAA4979H

1 FEATURES

- Digital YUV input according to ITU 656 standard
- 4 : 2 : 2 field rate upconversion (50 to 100 Hz or 60 to 120 Hz)
- 3.5-Mbit embedded DRAM
- Sample rate conversion for linear zoom and compression
- Panorama mode
- Dynamic noise reduction
- Noise estimator
- Black bar detection
- Luminance horizontal smart peaking
- Digital Colour Transient Improvement (DCTI)
- Triple 10-bit Digital-to-Analog Converter (DAC)
- Line-locked PLL
- Expansion port for SAA4992H and SAA4991WP
- Double window and Picture-In-Picture (PIP) processing
- Embedded 80C51 microcontroller
- 32-Kbyte internal ROM (mask programmable)
- 512-byte internal RAM



- I²C-bus controlled
- Synchronous No parity Eight bit Reception and Transmission (SNERT) interface
- Boundary Scan Test (BST).

2 GENERAL DESCRIPTION

The SAA4979H provides an economic stand-alone solution for 4 : 2 : 2 field rate upconversion (50 to 100 Hz or 60 to 120 Hz) including the required field memory combined with picture improvement features and dynamic field based noise reduction. The IC contains two digital input channels to allow field or frame based picture-in-picture processing. It also offers a feature expansion port for vector based motion estimation and compensation ICs such as SAA4991WP or SAA4992H.

3 QUICK REFERENCE DATA

SYMBOL	PARAMETER	MIN.	TYP.	MAX.	UNIT
V _{DDD}	digital supply voltage	3.0	3.3	3.6	V
V _{DDA}	analog supply voltage	3.15	3.30	3.45	V
V _{DDO} ; V _{DDI}	I/O supply voltage	3.0	3.3	3.6	V
V _{DDP}	protection supply voltage	3.0	5.0	5.5	V
I _{DDD}	digital supply current	–	120	160	mA
I _{DDA}	analog supply current	–	40	50	mA
P _{tot}	total power dissipation	–	–	0.9	W
T _{amb}	ambient temperature	–20	–	+70	°C

4 ORDERING INFORMATION

TYPE NUMBER	PACKAGE		
	NAME	DESCRIPTION	VERSION
SAA4979H	QFP128	plastic quad flat package; 128 leads (lead length 1.6 mm); body 28 × 28 × 3.4 mm; high stand-off height	SOT320-2

Sample rate converter with embedded high quality dynamic noise reduction and expansion port

SAA4979H

5 BLOCK DIAGRAM

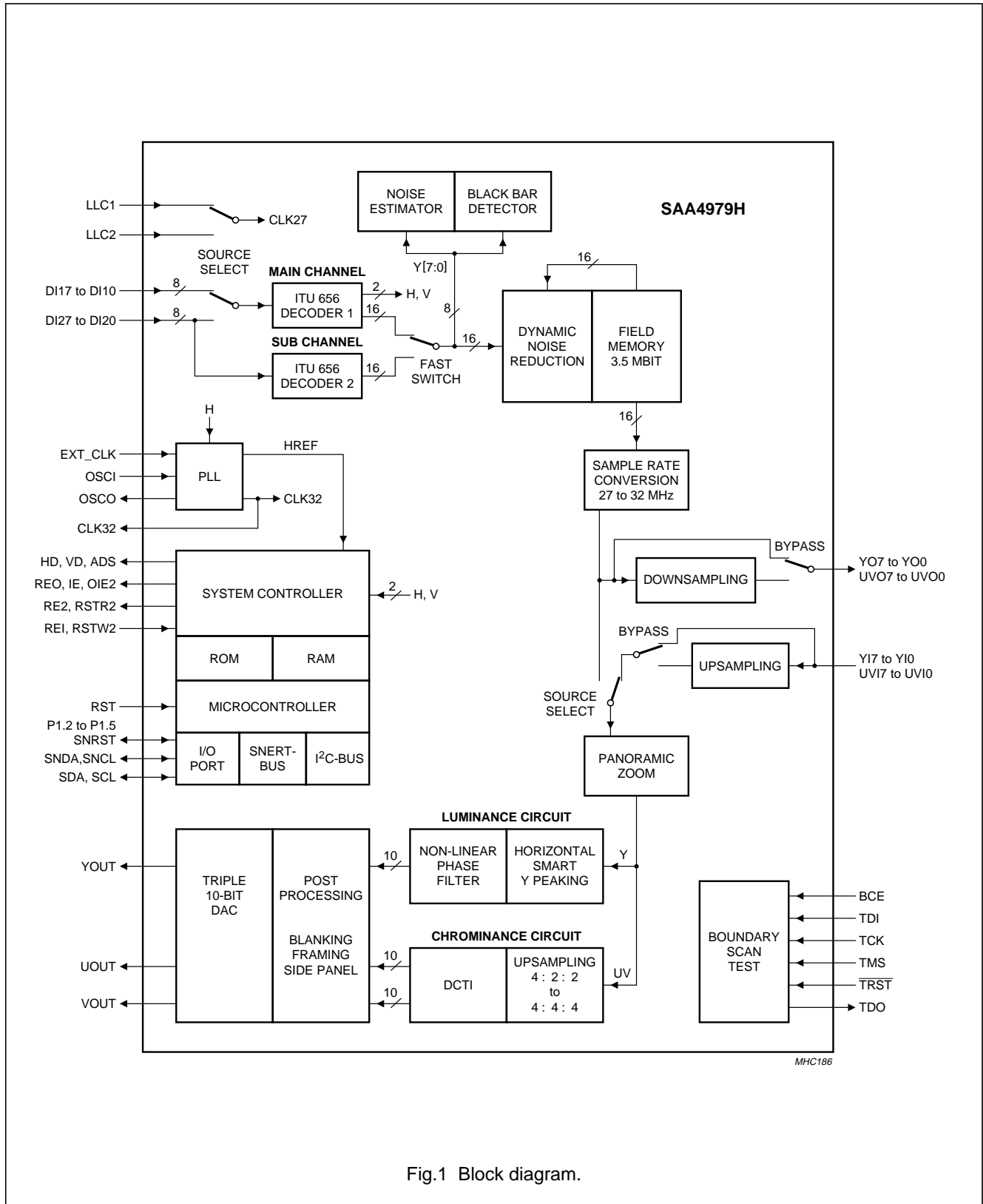

Fig.1 Block diagram.

Sample rate converter with embedded high quality dynamic noise reduction and expansion port

SAA4979H

6 PINNING

SYMBOL	PIN	TYPE	DESCRIPTION
V _{DDO1}	1	supply	I/O supply voltage 1 (3.3 V)
RSTR2	2	digital output (test input)	reset read, source 2
RE2	3	digital output (test input)	read enable, source 2
OIE2	4	digital output (test input)	output/input enable, source 2
V _{SSO1}	5	ground	I/O ground 1
RSTW2	6	digital input	reset write, source 2
DI10	7	digital input	ITU 656 input bit 0 (LSB), source 1
DI11	8	digital input	ITU 656 input bit 1, source 1
DI12	9	digital input	ITU 656 input bit 2, source 1
DI13	10	digital input	ITU 656 input bit 3, source 1
DI14	11	digital input	ITU 656 input bit 4, source 1
DI15	12	digital input	ITU 656 input bit 5, source 1
DI16	13	digital input	ITU 656 input bit 6, source 1
DI17	14	digital input	ITU 656 input bit 7 (MSB), source 1
V _{SSD1}	15	ground	digital ground 1
LLC1	16	digital input	27 MHz clock signal, source 1
V _{DDD1}	17	supply	digital supply voltage 1 (3.3 V)
V _{DDP}	18	supply	protection supply voltage (5 V)
DI20	19	digital input	ITU 656 input bit 0 (LSB), source 2
DI21	20	digital input	ITU 656 input bit 1, source 2
DI22	21	digital input	ITU 656 input bit 2, source 2
DI23	22	digital input	ITU 656 input bit 3, source 2
DI24	23	digital input	ITU 656 input bit 4, source 2
DI25	24	digital input	ITU 656 input bit 5, source 2
DI26	25	digital input	ITU 656 input bit 6, source 2
DI27	26	digital input	ITU 656 input bit 7 (MSB), source 2
V _{SSD2}	27	ground	digital ground 2
LLC2	28	digital input	27 MHz clock signal, source 2
V _{DDD2}	29	supply	digital supply voltage 2 (3.3 V)
TCK	30	digital input	test clock
TDI	31	digital input	test data input
TMS	32	digital input	test mode select
TRST	33	digital input	test reset (active LOW)
n.c.	34 to 41	–	not connected
TDO	42	digital output	test data output
V _{DDA1}	43	supply	analog supply voltage 1 (3.3 V)
YOUT	44	analog output	Y analog output
V _{SSA1}	45	ground	analog ground 1
UOUT	46	analog output	–(B – Y) analog output
V _{DDA2}	47	supply	analog supply voltage 2 (3.3 V)

Sample rate converter with embedded high quality
dynamic noise reduction and expansion port

SAA4979H

SYMBOL	PIN	TYPE	DESCRIPTION
VOUT	48	analog output	–(R – Y) analog output
V _{SSA2}	49	ground	analog ground 2
AGND	50	ground	analog ground (without substrate contacts)
BGEXT	51	analog I/O	band gap external I/O
V _{DDA3}	52	supply	analog supply voltage 3 (3.3 V)
V _{SSO2}	53	ground	I/O ground 2
HD	54	digital output	horizontal synchronisation output, display part
VD	55	digital output	vertical synchronisation output, display part
V _{SSA3}	56	ground	analog ground 3
V _{DDI}	57	supply	I/O internal supply voltage (3.3 V)
OSCI	58	analog input	oscillator input
OSCO	59	analog output	oscillator output
CLKEXT	60	digital input	external clock input
V _{DDD3}	61	supply	digital supply voltage 3 (3.3 V)
CLK32	62	digital output	32 MHz clock output
V _{SSD3}	63	ground	digital ground 3
V _{DDO2}	64	supply	I/O supply voltage 2 (3.3 V)
UVI0	65	digital input	UV digital input bit 0 (LSB)
UVI1	66	digital input	UV digital input bit 1
UVI2	67	digital input	UV digital input bit 2
UVI3	68	digital input	UV digital input bit 3
UVI4	69	digital input	UV digital input bit 4
UVI5	70	digital input	UV digital input bit 5
UVI6	71	digital input	UV digital input bit 6
UVI7	72	digital input	UV digital input bit 7 (MSB)
YI0	73	digital input	Y digital input bit 0 (LSB)
YI1	74	digital input	Y digital input bit 1
YI2	75	digital input	Y digital input bit 2
YI3	76	digital input	Y digital input bit 3
YI4	77	digital input	Y digital input bit 4
YI5	78	digital input	Y digital input bit 5
YI6	79	digital input	Y digital input bit 6
YI7	80	digital input	Y digital input bit 7 (MSB)
REI	81	digital input	read enable input
V _{SSO3}	82	ground	I/O ground 3
IE	83	digital output	input enable
REO	84	digital output	read enable output
YO7	85	digital output	Y digital output bit 7 (MSB)
YO6	86	digital output	Y digital output bit 6
YO5	87	digital output	Y digital output bit 5
YO4	88	digital output	Y digital output bit 4

Sample rate converter with embedded high quality
dynamic noise reduction and expansion port

SAA4979H

SYMBOL	PIN	TYPE	DESCRIPTION
V _{DDO3}	89	supply	I/O supply voltage 3 (3.3 V)
YO3	90	digital output	Y digital output bit 3
YO2	91	digital output	Y digital output bit 2
YO1	92	digital output	Y digital output bit 1
YO0	93	digital output	Y digital output bit 0 (LSB)
V _{SSO4}	94	ground	I/O ground 4
UVO7	95	digital output	UV digital output bit 7 (MSB)
UVO6	96	digital output	UV digital output bit 6
UVO5	97	digital output	UV digital output bit 5
UVO4	98	digital output	UV digital output bit 4
V _{DDO4}	99	supply	I/O supply voltage 4 (3.3 V)
UVO3	100	digital output	UV digital output bit 3
UVO2	101	digital output	UV digital output bit 2
UVO1	102	digital output	UV digital output bit 1
UVO0	103	digital output	UV digital output bit 0 (LSB)
V _{SSD4}	104	ground	digital ground 4
V _{DDD4}	105	supply	digital supply voltage 4 (3.3 V)
ADS	106	digital output	auxiliary display signal
SNCL	107	digital output	SNERT clock
SNDA	108	digital I/O	SNERT serial data
V _{SSO5}	109	ground	microcontroller I/O ground
SNRST	110	digital I/O	SNERT restart (port 1.0)
SDA	111	digital I/O	I ² C-bus serial data (port 1.7)
SCL	112	digital I/O	I ² C-bus clock (port 1.6)
P1.5	113	digital I/O	port 1 data input/output signal 5
P1.4	114	digital I/O	port 1 data input/output signal 4
P1.3	115	digital I/O	port 1 data input/output signal 3
P1.2	116	digital I/O	port 1 data input/output signal 2
V _{DDO5}	117	supply	microcontroller I/O supply voltage (3.3 V)
RST	118	digital input	microcontroller reset input
n.c.	119 to 127	–	not connected
BCE	128	digital input	boundary scan compliant enable

Sample rate converter with embedded high quality dynamic noise reduction and expansion port

SAA4979H

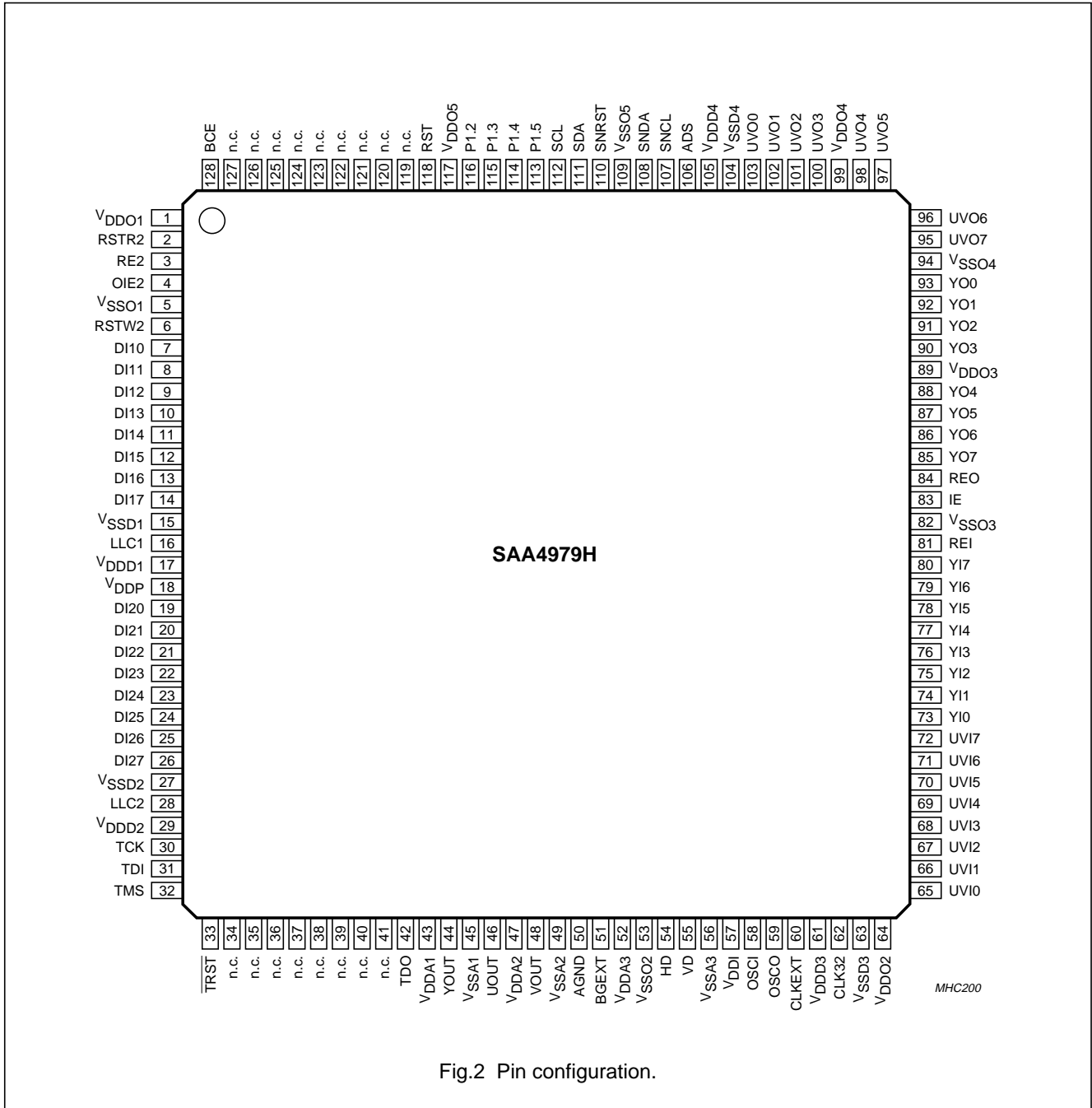

Fig.2 Pin configuration.

Sample rate converter with embedded high quality dynamic noise reduction and expansion port

SAA4979H

7 FUNCTIONAL DESCRIPTION

7.1 Digital processing at $1f_H$ level

7.1.1 ITU 656 DECODER

The SAA4979H provides 2 digital video input channels, which comply to the ITU 656 standard.

720 active video pixels per line are processed at a line-locked clock of 27 MHz, which has to be provided by the signal source. Luminance and chrominance information have to be multiplexed in the following order: C_{B1} , Y_1 , C_{R1} , Y_2 , ... Timing reference codes must be inserted at the beginning and end of each video line (see Table 1):

- A 'Start of Active Video' (SAV) code before the first active video sample (see Table 2)
- A 'End of Active Video' (EAV) code after the last active video sample (see Table 2).

The incoming active video data must be limited to 1 to 254, since the data words 00H and FFH are used for identification of the timing reference headers.

The digital signal input levels should comply to the CCIR-601 standard (see Fig.3). The data stream is decoded into the internal 4 : 2 : 2 YUV format at a 13.5 MHz clock rate. If required the sign of the UV signals can be inverted for both channels (control inputs: uv_sign1 and uv_sign2).

The signal source of the main channel can be selected from both inputs by the internal microcontroller (control input: Select_data_input1).

Table 1 ITU data format

BLANKING PERIOD			TIMING REFERENCE CODE (HEX)				720 PIXELS YUV 4 : 2 : 2 DATA										TIMING REFERENCE CODE (HEX)				BLANKING PERIOD		
...	80	10	FF	00	00	SAV	C_{B0}	Y_0	C_{R0}	Y_1	C_{B2}	Y_2	...	C_{R718}	Y_{719}	FF	00	00	EAV	80	10	...	

Table 2 SAV/EAV format

BIT 7	BIT 6 (F)	BIT 5 (V)	BIT 4 (H)	BIT 3 (P3)	BIT 2 (P2)	BIT 1 (P1)	BIT 0 (P0)
1	field bit 1st field: F = 0; 2nd field: F = 1	vertical blanking bit VBI: V = 1; active video: V = 0	H = 0 in SAV format; H = 1 in EAV format	reserved; evaluation not recommended (protection bits according to ITU 656)			

Sample rate converter with embedded high quality dynamic noise reduction and expansion port

SAA4979H

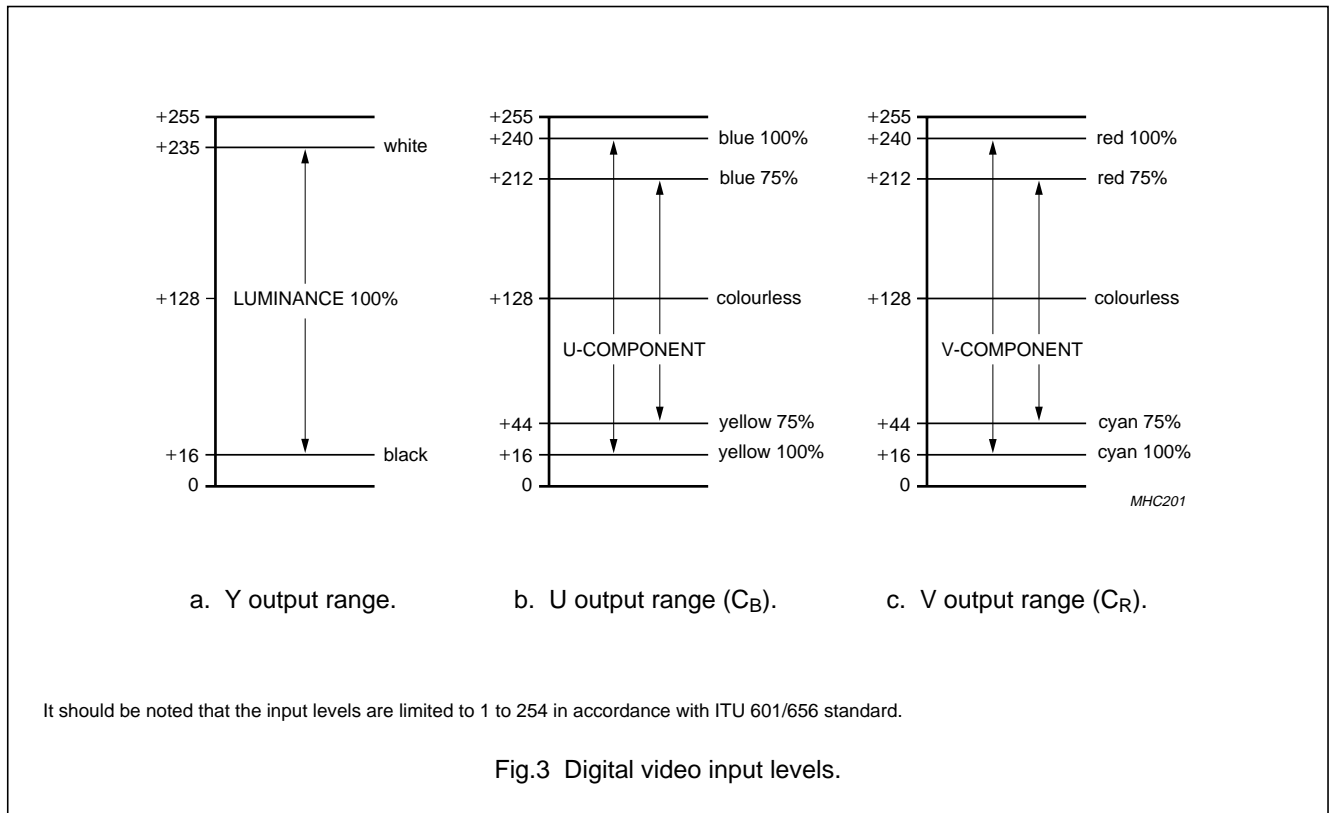

7.1.2 DOUBLE WINDOW AND PICTURE-IN-PICTURE PROCESSING

Data from the sub channel can be inserted into the data stream of the main channel by means of a fast switch. The two channels can be used together with one or two external field memories to implement, for example, double window or PIP processing. Both field based and frame based PIP processing is supported. The synchronization of the sub channel to the main channel is achieved by providing synchronized read signals (RE2 and RSTR2) for the external field memories, whereas the write signals need to be provided together with the incoming data by the external signal source.

A multi-PIP mode is also supported by freezing the data in the internal field memory within certain areas via the programmable internal control signal IE_{int} .

7.1.3 BLACK BAR DETECTOR

Black bar detection searches for the last black line in the upper part of the screen and for the first black line in the lower part of the screen. The detection is done within a programmable window (control inputs: bbd_hstart , bbd_hstop , bbd_vstart and bbd_vstop). To avoid disturbances of LOGOs in the video, the window can be shifted to the horizontal centre of the lines. A video line is considered to be black if the luminance values of that line within the detection window are not greater than a certain slice level (control input: bbd_slice_level) for more than a specific number of pixels (control input: bbd_event_value).

The numbers of the first and the last active video line can be read out by the microcontroller (control outputs: $bbd_1st_videoline$ and $bbd_last_videoline$).

Sample rate converter with embedded high quality dynamic noise reduction and expansion port

SAA4979H

7.1.4 DYNAMIC NOISE REDUCTION

The main function of the noise reduction is shown in Fig.4. It is divided into two signal paths for chrominance and luminance. In principal two operating modes can be used, the fixed and the adaptive mode. In both modes the applied frequency range, in which the noise reduction takes place, can be reduced or not reduced (control input: unfiltered).

The noise reduction operates field recursive with an averaging ratio (K factor) between fresh (new) and over previous fields averaged (old) luminance and chrominance values. Noise reduction can be activated by forcing the NREN control bit to HIGH. If NREN is LOW the noise reduction block is bridged via a data multiplexer.

In the fixed mode, the noise reduction produces a constant weighted input averaging. Because of smearing effects this mode should not be used for normal operation except for $K = 1$. The fixed mode can be activated separately for chrominance (control input: chromafix) and luminance (control input: lumafix).

In the adaptive mode, the averaging ratio is based on the absolute differences of the inputs of luminance and chrominance respectively. If the absolute difference is low, only a small part of the fresh data will be added. In cases of high difference, much of the fresh data will be taken. This occurs either in situations of movement or where a significant vertical contrast is seen. The relationship between the amount of movement and the K factor values is defined in a look-up table where the steps can be programmed (control input: Kstep).

It should be noted that recursion is done over fields, and that pixel positions between the new and old fields always have a vertical offset of one line. So averaging is not only done in the dimension of time but also in the vertical direction. Therefore averaging vertically on, for example, a vertical black to white edge would produce a grey result.

The averaging in chrominance can optionally be slaved to the luminance averaging (control input: Klumatochroma), in that case chrominance differences are not taken into account for the K factor setting of the chrominance signal path.

The noise reduction scheme also decreases the cross-colour patterns effectively if the adaptive noise reduction for the averaging in chrominance is slaved to the luminance averaging (control input: Klumatochroma). The cross-colour pattern does not produce an increase of the measured luminance difference, therefore this pattern will be averaged over many fields.

Sample rate converter with embedded high quality dynamic noise reduction and expansion port

SAA4979H

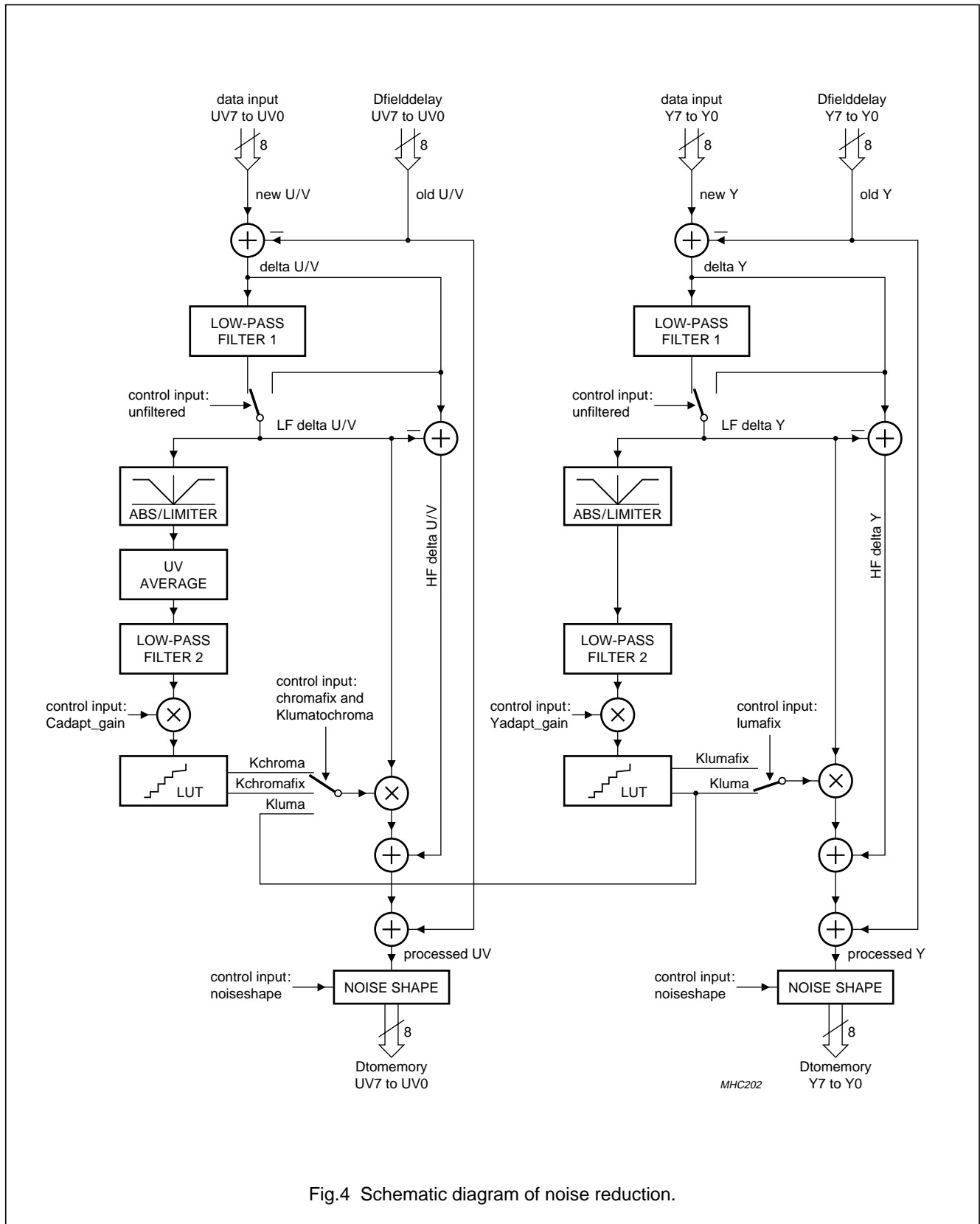

Fig.4 Schematic diagram of noise reduction.

Sample rate converter with embedded high quality dynamic noise reduction and expansion port

SAA4979H

7.1.4.1 Band-splitting

The frequencies of the difference signals of luminance (delta Y) and chrominance (delta U/V) can be split optionally into an upper band (HF) and a lower band (LF) with a low-pass filter in both signal paths. The lower frequency band signals (LF delta Y and LF delta U/V) are used as input for the noise reduction function.

The lower frequency band of the difference signals can also be used for the motion detection. If, for example, only the lower frequency band contains information, the specific picture content does not move or is moving slowly.

Optionally it is possible to bridge the band-splitting (control input: unfiltered = 1).

7.1.4.2 Motion detection

The same signals (the noise reduction is applied to) are also used to detect the amount of motion in the difference signals. Therefore, the absolute values of the difference signals are generated and limited to a maximum value. The absolute values of the difference signal of U and V are then averaged. The signals are low-pass filtered for smoothing these signals. The filtered signals are amplified, depending on the setting of the control inputs: Yadapt_gain and Cadapt_gain respectively.

The amplified signals, which correlate to the amount of movement in the chrominance or luminance signal path, are transferred into 1 out of 9 possible K factor values via look-up tables. The look-up tables consist of 9 intervals, each related to one K factor. The boundaries between the 9 intervals are defined by 8 programmable steps (control inputs: Kstep0 to Kstep7). The step values are valid for the look-up tables for both the chrominance and the luminance path. For example, signal values between Kstep2 and Kstep3 result in a K factor of $K = \frac{3}{8}$.

7.1.4.3 K factor

The amount of noise reduction (field averaging) is described by means of the K factor. When $K = 1$ no averaging is applied and the new field information is used. When $K = 0$ no averaging is applied and thus only the old field information is used like in a still picture mode. All values inbetween mean that a weighted averaging is applied. It is possible to use fixed K factor values if the control inputs lumafix or chromafix are set to logic 1. The possible fixed K factor values of the control inputs Klumafix and Kchromafix are given in Table 6.

7.1.4.4 Noise shape

Possible shadow picture information in the chrominance and luminance path, resulting from a low K factor value, will be eliminated if the noise shaping is activated. The noise shaping function can be switched off via the microcontroller (control input: noiseshape).

7.1.5 NOISE ESTIMATOR

The noise level of the luminance signal can be measured within a programmable window (control inputs: ne_hstart, ne_hstop, ne_vstart and ne_vstop). The correlation in flat areas is used to estimate the noise in the video signal. A large number of estimates of the noise is calculated for every video field. Such an estimate is obtained by summing absolute differences between current pixel values and delayed pixel values within blocks of 4 pixels. Within the lower part of the total range of possible estimates 15 intervals are defined. Each interval is defined by a lower boundary and an upper boundary. The lower boundary is equal to the number of the interval, whereas the upper boundary has a fixed relationship to the lower boundary (control input: gain_upbnd).

The lower boundary is increased or decreased by 1 in each field until an interval is found which contains at least a predefined number of estimates, and is at the same time lowest in the range. The value of the lower boundary of this interval determines the current noise figure output. The predefined number of estimates can be set via the microcontroller (control input: wanted_value), and good results were obtained with a value which is approximately 0.27% of the total number of blocks.

For video fields with a lot of noise the number of small differences is very low, that means the number of noise estimates in the lower intervals is close to 0. Contrary to this, for clean sequences this number is very high. This means that for clean sequences the noise estimate figure will be close to 0, and for sequences with a lot of noise the noise estimate figure (control output: nest) will reach 15.

To improve the performance of the noise estimator, several functions are implemented which can be controlled by the microcontroller. To increase the sensitivity of the noise measurement a prefilter with different gain settings is available (control input: Ypscale). Since the video content, e.g. sequences with a lot of high frequencies, can influence the noise estimate figure, a detail-counter is built-in.

Sample rate converter with embedded high quality dynamic noise reduction and expansion port

SAA4979H

The detail-counter calculates the number of absolute differences between current and previous pixels within a programmable interval defined by the control inputs `lb_detail` and `upb_detail`. The result of the 16-bit detail-counter (control outputs: `detail_cnt_h` and `detail_cnt_l`) can be used to increase or decrease the result of the noise estimation figure (control input: `compensate`).

In order to reduce the effect of clipping, only the blocks where the sum of the luminance value is within a predefined range are taken into account. The control signal `clip_offs` can be used to increase or decrease this range. A grey-counter gives information whether enough pixels with values in the grey range are present in a video field (control output: `grey_cnt`). When this number is lower than a predefined threshold, e.g. for complete fields towards black or white, all blocks are taken into account.

7.2 Embedded DRAM

7.2.1 3.5-MBIT FIELD MEMORY

The basic functionality of the field memory, which is shown in Fig.5, is similar to the SAA4956TJ. The memory size is extended to 3538944 bits. The data path is 16-bit wide (8-bit chrominance and 8-bit luminance). The field memory is capable of storing, for example, up to 307 video lines of 720 pixels in a 4 : 2 : 2 format. After writing or reading 18 words of 16-bit width, a data transfer is performed from the serial to parallel data registers (writing) or from the parallel to the serial registers (reading). The field memory has one write interface (controller and registers) to store $1f_H$ data and two read interfaces, one to read field delayed $1f_H$ data for the noise reduction function and the other to read $2f_H$ data for the following data processing. Since two asynchronous clock domains are involved (SWCKint as $1f_H$ clock and SRCKint as $2f_H$ clock) the read and write access to the memory array is controlled asynchronously by the memory arbitration logic triggered via request and acknowledge pulses.

The write operation starts with a reset write (RSTWint) address pointer operation during the write enable (WEint) LOW phase. The RSTWint LOW-to-HIGH transition, referred to the rising edge of the write clock SWCKint, must be at least 18 clock cycles ahead of the first written data (WEint HIGH) and 18 clock cycles after the last written data. The reset write transfers data temporarily stored in the serial write registers to the memory array and resets the write counter to the lowest address. Write enable (WEint) is used to enable or disable a data write operation. The WEint signal controls the data inputs D0 to D15.

In addition, the internal write address pointer is incremented if WEint is HIGH at the positive transition of the SWCKint write clock. The data is latched if WEint was HIGH at the previous positive transition of SWCKint. Input enable (IEint) LOW can also suppress the storage of the data into the memory array but does not influence the write pointer increment. It is used to freeze parts of the field data e.g for PIP processing.

The read operation starts with a reset (RSTRint) of the read address pointer during the read enable (REint) LOW phase. The RSTRint LOW-to-HIGH transition, referred to the rising edge of the read clock SRCKint, must be at least 18 clock cycles ahead of the first read data (REint HIGH) and 18 clock cycles after the last read data. The reset read resets the read counter to the lowest address and requests a read operation of the data of the lowest address to the serial read register. Read enable (REint) is used to enable or disable the read operation. The REint controls the data outputs Q0 to Q15. REint HIGH increments the read counter.

In parallel to the write operation a read2 operation is done using the same control signals as the write operation: SWCKint, WEint and RSTWint. It reads the old data of the previous field. The data Qold is needed as data input (Dfielddelay) for the noise reduction.

When the WEint signal is HIGH it indicates that active video (valid $1f_H$ data) is to be stored. The start of WEint HIGH is triggered by the H and V status bits of the ITU data stream. The start of WEint HIGH can be delayed by the control signals `weint_hstart` (number of clock delays) and `weint_vstart` (number of video lines delay). The stop of WEint HIGH is controlled by `weint_hstop` and `weint_vstop`.

When the IEint signal is HIGH it indicates that active video (valid $1f_H$ data) is also to be stored. The video data is not stored and earlier written data is maintained (frozen) if WEint is HIGH and IEint is LOW. The start of IEint HIGH is triggered by the H and V status bits of the ITU data stream. The start of IEint HIGH can be delayed by the control signals `ieint_hstart` (number of clock delays) and `ieint_vstart` (number of video lines delay). The stop of IEint HIGH is controlled by `ieint_hstop` and `ieint_vstop`.

RSTWint is triggered by the V status bit of the ITU data stream.

RSTRint is identical to the VD output signal.

REint is provided by the following sample rate conversion to gather $2f_H$ data if it is needed.

Sample rate converter with embedded high quality dynamic noise reduction and expansion port

SAA4979H

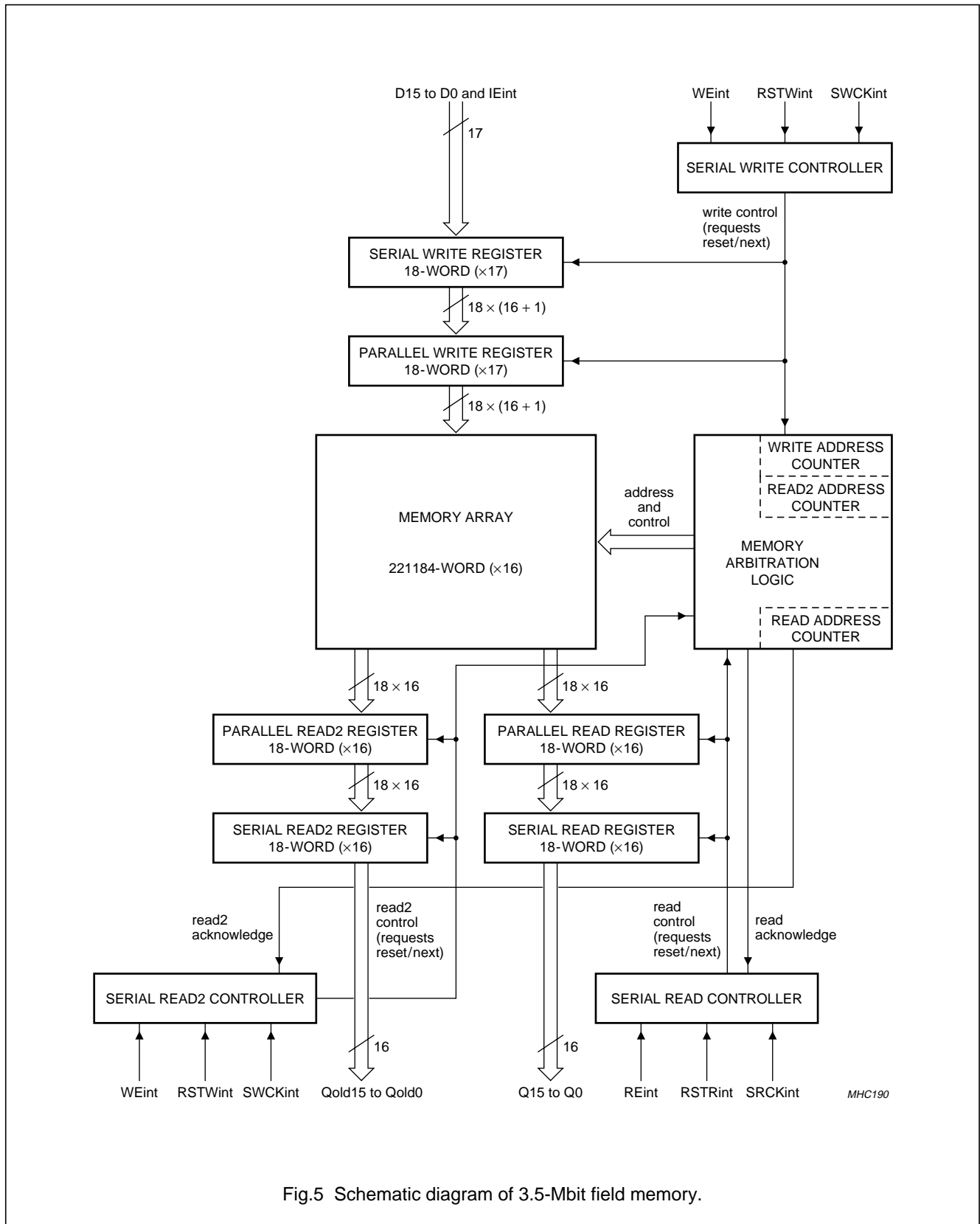

Fig.5 Schematic diagram of 3.5-Mbit field memory.

Sample rate converter with embedded high quality dynamic noise reduction and expansion port

SAA4979H

7.3 Digital processing at $2f_H$ level

7.3.1 SAMPLE RATE CONVERSION

The sample rate conversion block is used to obtain 848 active pixels per line out of the original 720 pixels according to the relation of the two sampling frequencies (32 MHz and 27 MHz). The interpolation for phase positions between the original samples is achieved with a variable phase delay filter with 10 taps for luminance signals and 6 taps for chrominance signals.

The conversion to a higher sample frequency of 32 MHz is done to improve the motion estimation performance in combination with external feature ICs, which can process up to 848 pixels per line at a 32 MHz clock. Bypassing this function keeps the original 720 pixels per line (control input: `bypass_FSRC`).

7.3.2 EXPANSION PORT

For a further extension of the system an expansion port is available, which is applicable for either a 4 : 2 : 2 format or a reduced 4 : 1 : 1 format for data input and output at a 32 MHz line-locked clock; see Table 3. However, the internal data is processed in a 8-bit wide 4 : 2 : 2 format.

To generate the 4 : 1 : 1 format at the output the U and V samples from the 4 : 2 : 2 data stream are filtered by a low-pass filter, before being subsampled with a factor of 2 and formatted to 4 : 1 : 1 format. Bypassing this function keeps the data in the 4 : 2 : 2 format.

An internal bandwidth detector is implemented to detect whether the colour difference signals provide either the full 4 : 2 : 2 bandwidth or a reduced 4 : 1 : 1 bandwidth.

Therefore absolute differences between original data and downsampled data are calculated and can be read out by the microcontroller (control output: `UV_bw_detect`). Low absolute differences indicate that the original data does not contain the full 4 : 2 : 2 bandwidth. This information can be used to switch the upsample and downsample filter on or off (control inputs: `bypass_upsampling` and `bypass_downsampling`). Bandwidth detection is done within a programmable window (control inputs: `bw_hstart`, `bw_hstop` and `bw_vstart`, `bw_vstop`).

In the event of a 4 : 1 : 1 format at the input an upconverter to 4 : 2 : 2 is applied with a linear interpolation filter for creation of the extra samples. These are combined with the original samples from the 4 : 1 : 1 stream.

The first phase of the YUV data stream is available on the output bus two clock cycles after the rising edge of the REI input signal. The start position, when the first phase of the YUV data stream arrives on the input bus, can be set via the control register `exp_hstart`.

The luminance output signal is in 8-bit straight binary format, whereas the chrominance output signals are in twos complement format. The input data at the expansion slot is expected in the same format. U and V input signals are inverted if the corresponding control bit `mid_uv_inv` is set.

Table 3 YUV formats

OUTPUT PIN	4 : 1 : 1 FORMAT				4 : 2 : 2 FORMAT		INPUT PIN
YO7	Y07	Y17	Y27	Y37	Y07	Y17	YI7
YO6	Y06	Y16	Y26	Y36	Y06	Y16	YI6
YO5	Y05	Y15	Y25	Y35	Y05	Y15	YI5
YO4	Y04	Y14	Y24	Y34	Y04	Y14	YI4
YO3	Y03	Y13	Y23	Y33	Y03	Y13	YI3
YO2	Y02	Y12	Y22	Y32	Y02	Y12	YI2
YO1	Y01	Y11	Y21	Y31	Y01	Y11	YI1
YO0	Y00	Y10	Y20	Y30	Y00	Y10	YI0
UVO7	U07	U05	U03	U01	U07	V07	UVI7
UVO6	U06	U04	U02	U00	U06	V06	UVI6
UVO5	V07	V05	V03	V01	U05	V05	UVI5
UVO4	V06	V04	V02	V00	U04	V04	UVI4
UVO3	–	–	–	–	U03	V03	UVI3
UVO2	–	–	–	–	U02	V02	UVI2
UVO1	–	–	–	–	U01	V01	UVI1
UVO0	–	–	–	–	U00	V00	UVI0

Sample rate converter with embedded high quality dynamic noise reduction and expansion port

SAA4979H

7.3.3 PANORAMIC ZOOM

The panoramic zoom block contains a second sample rate converter, which performs the following tasks:

- Linear horizontal sample rate conversion in both zoom and compress direction, with a sample rate conversion factor between 0 and 2, meaning infinite zoom up to a compression with a factor of 2
- Dynamic sample rate conversion e.g. for panorama mode display of 4 : 3 material on a 16 : 9 screen.

For linear horizontal zoom or compression the sample rate conversion factor is static during a video line (control input: c0). Positive values of c0 are suitable for compression, negative values result in expansion.

In panorama mode the video lines are geometrically expanded towards the sides. The sample rate conversion factor is modulated along the video line. A parabolic shape of the sample rate conversion factor can be obtained with the parameter c2, which controls the second order variation of the sample rate. Negative values of c2 are suitable for panorama mode, positive values result in the inverse mode (amaronap mode).

The panoramic zoom block also provides a dynamically controlled delay with an accuracy up to $\frac{1}{64}$ of a pixel and a range of -0.5 to +0.5 lines (control input: hshift).

Sufficient accuracy in interpolation for phase positions between the original samples is achieved with a variable phase delay filter with 10 taps for luminance signals and 6 taps for chrominance signals.

7.3.4 DIGITAL COLOUR TRANSIENT IMPROVEMENT

The Digital Colour Transient Improvement (DCTI) is intended for U and V signals originating from a 4 : 1 : 1 source. Horizontal transients are detected and enhanced without overshoots by differentiating, make absolute and again differentiating the U and V signals separately. This results in a 4 : 4 : 4 U and V bandwidth. To prevent third-harmonic distortion, which is typical for this processing, a so called over the hill protection prevents peak signals becoming distorted.

It is possible to control the following settings via the microcontroller: gain width (see Fig.10), threshold (i.e. immunity against noise), selection of simple or improved first differentiating filter (see Fig.9), limit for pixel shift range (see Fig.11), common or separate processing of U and V signals, hill protection mode (i.e. no discolourations in narrow colour gaps), low-pass filtering for U and V signals (see Fig.12) and a so called super hill

mode, which avoids discolourations in transients within a colour component.

7.3.5 HORIZONTAL SMART Y PEAKING

A linear peaking is applied, which amplifies the luminance signal in the middle and the upper ranges of the bandwidth.

The filtering is an addition of:

- The original signal
- The original signal high-passed with maximum gain at a frequency of $\frac{1}{2}f_s$ (sample frequency $f_s = 32$ MHz)
- The original signal band-passed with a centre frequency of $\frac{1}{4}f_s$
- The original signal band-passed with a centre frequency of 4.76 MHz.

The band-passed and high-passed signals are weighted with the factors 0, $\frac{1}{16}$, $\frac{2}{16}$, $\frac{3}{16}$, $\frac{4}{16}$, $\frac{5}{16}$, $\frac{6}{16}$ and $\frac{8}{16}$, resulting in a maximum gain difference of 2 dB per step at the centre frequencies.

Coring is added to avoid amplification of low amplitudes in the high-pass and band-pass filtered signals, which are considered to be noise. The coring threshold can be programmed as 0 (off), ± 4 , ± 8 , ± 12 to ± 60 LSB with respect to the (signed) 10-bit signal.

In addition the peaking gain can be reduced depending on the signal amplitude, programming range 0 (no attenuation), $\frac{1}{4}$, $\frac{2}{4}$ and $\frac{4}{4}$. It is also possible to make larger undershoots than overshoots, programming range 0 (no attenuation of undershoots), $\frac{1}{4}$, $\frac{2}{4}$ and $\frac{4}{4}$.

A steepness detector is built-in, which provides information for dynamic control of the peaking. For that the maximum absolute value of the band-pass filtered signal within a video field is calculated and can be read out by the microcontroller (control output: steepness_max).

7.3.6 NON-LINEAR PHASE FILTER

The non-linear phase filter adjusts possible group delay differences in the Y, U and V output channels. The filter coefficients are: $[-\lambda \times (1 - \mu); 1 + \lambda; -\lambda \times \mu]$ where λ determines the strength of the filter and μ determines the asymmetry. The effect of the asymmetry is a decrease in the delay for higher frequencies with $\mu \leq 0.5$. Control settings are provided for $\lambda = 0, \frac{1}{8}, \frac{2}{8}, \frac{3}{8}$ and $\mu = 0, \frac{1}{4}, \frac{1}{2}$.

Sample rate converter with embedded high quality dynamic noise reduction and expansion port

SAA4979H

7.3.7 POST PROCESSING

Blanking is done just before the digital-to-analog conversion by switching Y to a fixed black value and UV to a colourless value. The blanking window is defined by the control inputs: `bln_hstart`, `bln_hstop`, `bln_vstart` and `bln_vstop`.

Side panels are generated by switching the Y, U and V to defined values within a horizontal window (control inputs: `sidepanel_hstart` and `sidepanel_hstop`); the 8 MSBs of Y and the 4 MSBs of U and V are programmable (control inputs: `sidepanel_y`, `sidepanel_u` and `sidepanel_v`).

Framing e.g. for picture-in-picture mode, can be achieved by another programmable window (control inputs: `PIP_frame_hstart`, `PIP_frame_hstop`, `PIP_frame_vstart` and `PIP_frame_vstop`). The vertical and horizontal frame width can be programmed from 1 up to 15 pixels (control inputs: `PIP_frame_height` and `PIP_frame_width`). Framing uses the same colour and luminance values as the side panels.

The range of the Y output signal can be chosen between 9 and 10 bits (control input: `output_range`). In the event of 9 bits for the nominal signal there is room left for under and overshoot, adding up to a total of 10 bits. In the event of selecting all 10 bits of the luminance digital-to-analog converter for the nominal signal any under or overshoot will be clipped (see Fig.6).

The Y samples can be shifted onto 16 positions with respect to the UV samples (control input: `y_delay`). The zero delay setting is suitable for the nominal case of aligned input data. The other settings provide eight samples with less delay to seven samples with more delay in Y.

7.4 Triple 10-bit digital-to-analog conversion

Three identical 10-bit converters are used to map the 4 : 4 : 4 YUV data to analog levels with a 32 MHz data rate. The polarity of the colour difference signals U and V is switchable by the control bit `uv_inv_out`. The output ranges are illustrated in Figs 6 and 7 respectively.

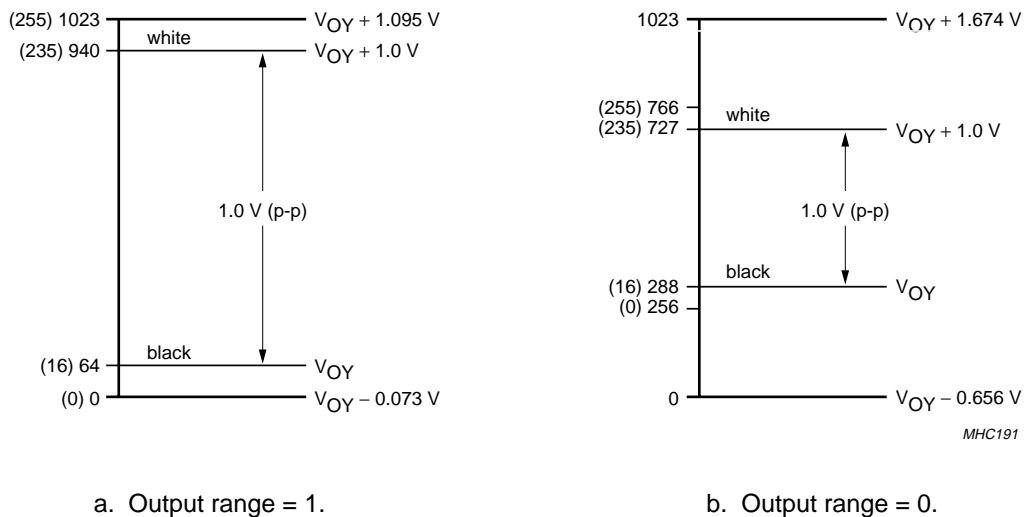
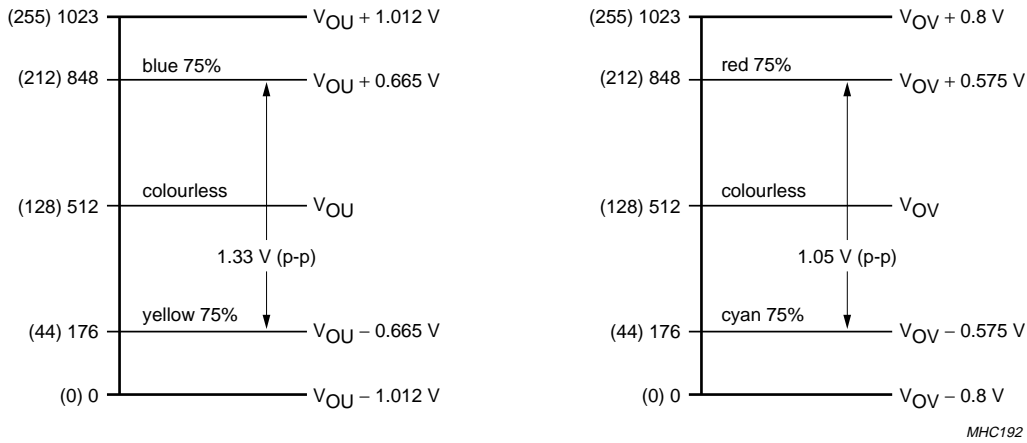

Fig.6 Luminance output levels.

Sample rate converter with embedded high quality dynamic noise reduction and expansion port

SAA4979H



a. U output level.

b. V output level.

Fig.7 Chrominance output levels.

7.5 Microcontroller

The SAA4979H contains an embedded 80C51 microcontroller core including 512-byte RAM and 32-Kbyte ROM. The microcontroller runs on a 16 MHz clock, generated by dividing the 32 MHz display clock by a factor of 2.

7.5.1 HOST INTERFACE

For controlling internal registers a host interface, consisting of a parallel address and data bus, is built-in. The interface can be addressed as internal AUXRAM via a MOVX type of instruction. The complete range of internal control registers and the corresponding host addresses are described in Section 8.1. User access to these control registers via the I²C-bus can be implemented in the embedded software.

7.5.2 I²C-BUS INTERFACE

The I²C-bus interface in the SAA4979H is used in a slave receive and transmit mode for communication with a central system microcontroller. The standardized bus frequencies of both 100 kHz and 400 kHz can be accommodated.

The I²C-bus slave address of the SAA4979H is 0110100 R/W. During slave transmit mode the SCL LOW period may be extended by pulling SCL to LOW (in accordance with the I²C-bus specification).

Detailed information about the software dependent I²C-bus subaddresses of the control registers and a detailed description of the transmission protocol can be found in Application Note "I²C-bus register specification of the SAA4979H".

7.5.3 SNERT-BUS INTERFACE

A SNERT interface is built-in, which operates in a master receive and transmit mode for communication with peripheral circuits such as SAA4991WP or SAA4992H. The SNERT interface replaces the standard UART interface. Contrary to the 80C51 UART interface there are additional special function registers (see Table 10) and there is no byte separation time between address and data.

Sample rate converter with embedded high quality dynamic noise reduction and expansion port

SAA4979H

The SNERT interface transforms the parallel data from the microcontroller into 1 or 2 Mbaud SNERT data, switchable via microcontroller. The SNERT-bus consists of three signals: SNCL used as serial clock signal, generated by the SNERT interface; SNDA used as bidirectional data line and SNRST used as reset signal, generated by the microcontroller at port pin P1.0 to indicate the start of a transmission.

The read or write operation must be set by the microcontroller. When writing to the bus, 2 bytes are loaded by the microcontroller: one for the address, the other for the data. When reading from the bus, one byte is loaded by the microcontroller for the address, the received byte is the data from the addressed SNERT location.

7.5.4 I/O PORTS

A parallel 8-bit I/O port (P1) is available, where P1.0 is used as SNERT reset signal (SNRST), P1.2 to P1.5 can be used for application specific control signals, and P1.6 and P1.7 are used as I²C-bus signals (SCL and SDA).

7.5.5 WATCHDOG TIMER

The microcontroller contains an internal Watchdog timer, which can be activated by setting the corresponding special function register PCON.4. Only a synchronous reset will clear this bit. To prevent a system reset the Watchdog timer must be reloaded within a specified time. The Watchdog timer contains an 11-bit prescaler and is therefore incremented every 0.768 ms (16 MHz clock). The time interval between the timers reloading and the occurrence of a reset depends on the reloaded 8-bit value.

7.5.6 RESET

A reset is accomplished by holding the RST pin HIGH for at least 0.75 μ s while the display clock is running and the supply voltage is stabilized.

7.6 System controller

The system controller provides all necessary internal read and write signals for controlling the embedded field memory. The required control signals (REO and IE) for applications with motion compensation circuits and the drive signals (HD and VD) for the horizontal and vertical deflection power stages are also generated.

The system controller also supports double window or picture-in-picture processing in combination with an external field memory by providing the required memory control signals (RE2, RSTW2 and OIE2).

The system controller is connected to the microcontroller via the host interface.

7.6.1 READ ENABLE OUTPUT

The Read Enable Output (REO) signal is intended for control of an external feature IC. It is a composite signal consisting of a horizontal and a vertical part. The horizontal and vertical positions are programmable (control inputs: reo_hstart, reo_hstop, reo_vstart and reo_vstop).

7.6.2 READ ENABLE INPUT

The Read Enable Input (REI) signal is used in applications with external feature ICs connected to the expansion port. It has to be provided by the external circuit (see Section 7.3.2).

7.6.3 INPUT ENABLE

The Input Enable (IE) signal is intended for control of field memories in applications together with an external feature IC connected to the expansion port. It can be directly set or reset via the microcontroller.

7.6.4 HORIZONTAL DEFLECTION

The Horizontal Deflection (HD) signal is for driving a deflection circuit; start and stop values of the horizontal position are programmable in a resolution of 4 clock cycles (control inputs: hd_start and hd_stop).

7.6.5 VERTICAL DEFLECTION

The Vertical Deflection (VD) signal is for driving a deflection circuit. This signal has a cycle time of 10 ms and the start and stop values of the vertical position are programmable in steps of 16 μ s (control inputs: vd_start and vd_stop).

7.6.6 AUXILIARY DISPLAY SIGNAL

The Auxiliary Display Signal (ADS) is for general purposes; the horizontal and vertical positions are programmable (control inputs: ads_hstart, ads_hstop, ads_vstart and ads_vstop).

7.6.7 READ ENABLE 2

The Read Enable 2 (RE2) signal is intended for control of an external field memory at input channel 2 in picture-in-picture applications. It is a composite signal consisting of a horizontal and a vertical part. The horizontal and vertical positions are programmable (control inputs: re2_hstart, re2_hstop, re2_vstart and re2_vstop).

Sample rate converter with embedded high quality dynamic noise reduction and expansion port

SAA4979H

7.6.8 OUTPUT/INPUT ENABLE 2

The Output/Input Enable 2 (OIE2) signal is intended for control of one or two external field memories at input channel 2 in picture-in-picture applications. It can be directly set or reset via the microcontroller.

7.6.9 RESET READ 2

The Reset Read 2 (RSTR2) signal is intended for control of the read access of an external field memory at input channel 2 in picture-in-picture applications. It is derived from the internal vertical reference signal of the main channel.

7.6.10 RESET WRITE 2

The Reset Write 2 (RSTW2) input is used in picture-in-picture applications with an external field memory at input channel 2, and has to be provided by an external circuit which controls the field memory write access.

7.7 Line-locked clock generation

An internal PLL generates the 32 MHz line-locked display clock CLK32. The PLL consists of a ring oscillator, DTO and digital control loop. The PLL characteristic is controlled by means of the microcontroller.

7.8 Boundary scan test

The SAA4979H has built-in logic and 6 dedicated pins to support boundary scan testing which allows board testing without special hardware (nails). The SAA4979H follows the "IEEE Std. 1149.1 - Standard Test Access Port and Boundary-Scan Architecture" set by the Joint Test Action Group (JTAG) chaired by Philips.

The 6 special pins are Test Mode Select (TMS), Test Clock (TCK), Test Reset (TRST), Test Data Input (TDI), Boundary-scan Compliant Enable (BCE) and Test Data Output (TDO). To achieve compliance to the "IEEE Std. 1149.1" a logic HIGH has to be applied to the BCE pin. Internal pull-up resistors at the input pins TMS, TRST and TDI are not implemented.

8 CONTROL REGISTER DESCRIPTION

8.1 Host interface detail

Table 4 Write register at 1f_H

HOST ADDRESS (HEX)	BIT	NAME	DESCRIPTION
Host address 0102H to 011CH (system control)			
0102	0 to 7	weint_vstart	write enable internal memory vertical start (lower 8 of 9 bits)
0103	0 to 7	weint_vstop	write enable internal memory vertical stop (lower 8 of 9 bits)
0104	0	weint_vstart (MSB)	write enable internal memory vertical start (MSB)
	1	weint_vstop (MSB)	write enable internal memory vertical stop (MSB)
	2	fm1_still	still picture mode; 0 = normal mode, 1 = still picture mode
	3	pip_2fm_dc	direct controlled PIP mode; 0 = normal mode, 1 = direct mode
	4	sfr	field recognition mode; 0 = normal mode, 1 = inverse mode
	5	sfm	single field mode; 0 = normal mode, 1 = single field mode
	6	re2_vstart (MSB)	read enable PIP window vertical start (MSB)
	7	re2_vstop (MSB)	read enable PIP window vertical stop (MSB)
0105	0 to 7	re2_vstart	read enable PIP window vertical start (lower 8 of 9 bits)
0106	0 to 7	re2_vstop	read enable PIP window vertical stop (lower 8 of 9 bits)
0107	0 to 7	re2_hstart	read enable PIP window horizontal start (lower 8 of 10 bits)
0108	0 to 7	re2_hstop	read enable PIP window horizontal stop (lower 8 of 10 bits)

Sample rate converter with embedded high quality dynamic noise reduction and expansion port

SAA4979H

HOST ADDRESS (HEX)	BIT	NAME	DESCRIPTION
0109	0 to 3	min_dist_maintosub	minimum distance between main and sub channel
	4	pip_raster_corr	PIP raster correction; 0 = off, 1 = on
	5	pip_on	PIP mode; 0 = off, 1 = on
	6	pip_2field	PIP 2-field mode; 0 = single field mode, 1 = 2-field mode
	7	mpip_on	multi-PIP mode; 0 = off, 1 = on
010A	0 to 7	dispvpos	vertical position of the display related to acquisition
0112	0 to 7	weint_hstart	write enable internal memory horizontal start (lower 8 of 10 bits)
0113	0 to 7	weint_hstop	write enable internal memory horizontal stop (lower 8 of 10 bits)
0114	0 to 1	weint_hstart (MSBs)	write enable internal memory horizontal start (higher 2 of 10 bits)
	2 to 3	weint_hstop (MSBs)	write enable internal memory horizontal stop (higher 2 of 10 bits)
	4 to 5	re2_hstart (MSBs)	read enable PIP window horizontal start (higher 2 of 10 bits)
	6 to 7	re2_hstop (MSBs)	read enable PIP window horizontal stop (higher 2 of 10 bits)
0116	0 to 7	h656int_hstart	internal H reference horizontal start; 4 pixel resolution
0117	0 to 7	h656int_hstop	internal H reference horizontal stop; 4 pixel resolution
0118	0 to 7	ieint_hstart	input enable internal memory horizontal start (lower 8 of 10 bits)
0119	0 to 7	ieint_hstop	input enable internal memory horizontal stop (lower 8 of 10 bits)
011A	0 to 7	ieint_vstart	input enable internal memory vertical start (lower 8 of 10 bits)
011B	0 to 7	ieint_vstop	input enable internal memory vertical stop (lower 8 of 10 bits)
011C	0 to 1	ieint_hstart (MSBs)	input enable internal memory horizontal start (higher 2 of 10 bits)
	2 to 3	ieint_hstop (MSBs)	input enable internal memory horizontal stop (higher 2 of 10 bits)
	4	ieint_vstart (MSB)	input enable internal memory vertical start (MSB)
	5	ieint_vstop (MSB)	input enable internal memory vertical stop (MSB)
	6 to 7	–	reserved
Host address 0185H to 018EH (noise estimator)			
0185	0 to 1	ypscale	scale of prefilter coefficients: ($\frac{1}{4}$, $\frac{1}{2}$, $\frac{1}{4}$, bypass prefilter)
	2 to 5	compensate	compensation value (4-bit signed)
	6 to 7	–	reserved
0186	0 to 2	gain_upbnd	gain of upper boundary: 0, 1, 2, 3, 4, 5, 6 and 7
	3	sob_negl	neglect sum over block value if HIGH
	4	sel_sob_negl	enable of control bit sob_negl: 0 = disable, 1 = enable
	5 to 6	clip_offs	clip offset: 1, 2, 4 and 8
	7	–	reserved
0187	0 to 7	wanted_value	wanted value in steps of $\frac{1}{256}\%$, i.e. predefined number of estimates; range: 0 to $\frac{255}{256}\%$
0188	0 to 7	lb_detail	lower boundary of detail counter
0189	0 to 7	upb_detail	upper boundary of detail counter
018A	0 to 7	ne_hstart	noise measurement window horizontal start; 4 pixel resolution
018B	0 to 7	ne_hstop	noise measurement window horizontal stop; 4 pixel resolution
018C	0 to 7	ne_vstart	noise measurement window vertical start (lower 8 of 9 bits)

Sample rate converter with embedded high quality dynamic noise reduction and expansion port

SAA4979H

HOST ADDRESS (HEX)	BIT	NAME	DESCRIPTION
018D	0 to 7	ne_vstop	noise measurement window vertical stop (lower 8 of 9 bits)
018E	0	ne_vstart (MSB)	noise measurement window vertical start (MSB)
	1	ne_vstop (MSB)	noise measurement window vertical stop (MSB)
	2 to 7	–	reserved
Host address 018FH (front-end control)			
018F	0	Select_data_input1	select data input for main channel: 0 = input 2, 1 = input 1
	1	uv_sign1	UV sign of main channel 1: 0 = unsigned, 1 = signed
	2	uv_sign2	UV sign of sub channel 2: 0 = unsigned, 1 = signed
	3 to 7	–	reserved
Host address 0190H to 0196H (noise reduction)			
0190	0 to 3	Kstep0	step in adaptive curve from $K = \frac{1}{16}$ to $K = \frac{1}{8}$; weight of 1
	4 to 7	Kstep1	step in adaptive curve from $K = \frac{1}{8}$ to $K = \frac{2}{8}$; weight of 1
0191	0 to 3	Kstep2	step in adaptive curve from $K = \frac{2}{8}$ to $K = \frac{3}{8}$; weight of 2
	4 to 7	Kstep3	step in adaptive curve from $K = \frac{3}{8}$ to $K = \frac{4}{8}$; weight of 2
0192	0 to 3	Kstep4	step in adaptive curve from $K = \frac{4}{8}$ to $K = \frac{5}{8}$; weight of 4
	4 to 7	Kstep5	step in adaptive curve from $K = \frac{5}{8}$ to $K = \frac{6}{8}$; weight of 4
0193	0 to 3	Kstep6	step in adaptive curve from $K = \frac{6}{8}$ to $K = \frac{7}{8}$; weight of 8
	4 to 7	Kstep7	step in adaptive curve from $K = \frac{7}{8}$ to $K = \frac{8}{8}$; weight of 8
0194	0 to 3	Klumafix	value of the fixed K factor of the luminance; see Table 6
	4 to 6	Yadapt_gain	value of the gain of the adaptive curve of the luminance; see Table 5
	7	lumafix	adaptive (lumafix = 0) or fixed K mode (lumafix = 1) of the luminance
0195	0 to 3	Kchromafix	value of the fixed K factor of the chrominance; see Table 6
	4 to 6	Cadapt_gain	value of the gain of the adaptive curve of the chrominance; see Table 5
	7	chromafix	adaptive (chromafix = 0) or fixed K mode (chromafix = 1) of chrominance
0196	0	Klumatochr	if HIGH: uses luminance K factor for chrominance path
	1	unfiltered	if HIGH: band splitting is deactivated, complete difference signals are used
	2	noiseshape	if HIGH: noise shaping is activated
	3	splitscreen	if HIGH: split screen demo mode is activated
	4	NREN	noise reduction enable; 0 = off; 1 = on
	5 to 7	–	reserved
Host address 019AH to 019FH (black bar detection)			
019A	0 to 5	bbd_event_value	black bar detection event value
	6 to 7	–	reserved
019B	0 to 5	bbd_slice_level	black bar detection slice level
	6	bbd_vstop (MSB)	black bar detection window vertical stop (MSB)
	7	bbd_vstart (MSB)	black bar detection window vertical start (MSB)
019C	0 to 7	bbd_hstart	black bar detection window horizontal start; 4 pixel resolution

Sample rate converter with embedded high quality
dynamic noise reduction and expansion port

SAA4979H

HOST ADDRESS (HEX)	BIT	NAME	DESCRIPTION
019D	0 to 7	bbd_hstop	black bar detection window horizontal stop; 4 pixel resolution
019E	0 to 7	bbd_vstart	black bar detection window vertical start (lower 8 of 9 bits)
019F	0 to 7	bbd_vstop	black bar detection window vertical stop (lower 8 of 9 bits)

Table 5 Gain settings of adaptive values for chrominance and luminance

Yadapt_gain/Cadapt_gain [2:0]		GAIN
HEX	DECIMAL	
00	0	$\frac{1}{8}$
01	1	$\frac{2}{8}$
02	2	$\frac{4}{8}$
03	3	$\frac{8}{8}$
04	4	$\frac{16}{8}$
05	5	$\frac{32}{8}$
06	6	$\frac{64}{8}$
07	7	$\frac{128}{8}$

Table 6 Settings of fixed K factor values

Klumafix/Kchromafix [3:0]		K factor
HEX	DECIMAL	
00	0	0
01	1	$\frac{1}{16}$
02	2	$\frac{2}{16}$
03	3	$\frac{3}{16}$
04	4	$\frac{4}{16}$
05	5	$\frac{5}{16}$
06	6	$\frac{6}{16}$
07	7	$\frac{7}{16}$
08	8	$\frac{8}{16}$
09	9	$\frac{9}{16}$
0A	10	$\frac{10}{16}$
0B	11	$\frac{11}{16}$
0C	12	$\frac{12}{16}$
0D	13	$\frac{13}{16}$
0E	14	$\frac{14}{16}$
0F	15	$\frac{16}{16}$

Sample rate converter with embedded high quality dynamic noise reduction and expansion port

SAA4979H

Table 7 Write register at 2f_H

HOST ADDRESS (HEX)	BIT	NAME	DESCRIPTION
Host address 0222H to 023FH (system control)			
0222	0 to 7	vd_vstart	vertical deflection pulse start (lower 8 of 11 bits)
0223	0 to 7	vd_vstop	vertical deflection pulse stop (lower 8 of 11 bits)
0224	0 to 7	reo_vstart	read enable output window vertical start (lower 8 of 10 bits)
0225	0 to 7	reo_vstop	read enable output window vertical stop (lower 8 of 10 bits)
0226	0 to 3	dspflds	number of display fields minus 1
	4 to 7	–	reserved
0227	0 to 1	reo_vstart (MSBs)	read enable output window vertical start (higher 2 of 10 bits)
	2 to 3	reo_vstop (MSBs)	read enable output window vertical stop (higher 2 of 10 bits)
	4 to 7	–	reserved
0228	0 to 2	vd_vstart (MSBs)	vertical deflection pulse start (higher 3 of 11 bits)
	3 to 4	vd_vstop (MSBs)	vertical deflection pulse start (higher 3 of 11 bits)
	6 to 7	–	reserved
0229	0 to 7	ads_hstart	auxiliary display signal horizontal start (lower 8 of 10 bits)
022A	0 to 7	ads_hstop	auxiliary display signal horizontal stop (lower 8 of 10 bits)
022B	0	vres_dis	internal vertical reset; 0 = enable; 1 = disable
	1	crn_direct	direct vertical frame synchronization; 0 = disable; 1 = enable
	2	dr_aabb	display raster mode; 0 = standard VD synchronization; 1 = AABB synchronization; VD delayed for the first 50 Hz field
	3	–	reserved
	4	gen_mode	generator mode; 0 = off; 1 = on
	5	ie_fm2	input enable signal (output IE)
	6	smooth_lock	smooth lock synchronization mode; 0 = off; 1 = on
	7	–	reserved
022C	0 to 7	ads_vstart	auxiliary display signal vertical start (lower 8 of 10 bits)
022D	0 to 7	ads_vstop	auxiliary display signal vertical stop (lower 8 of 10 bits)
022E	0 to 1	ads_hstart (MSBs)	auxiliary display signal horizontal start (higher 2 of 10 bits)
	2 to 3	ads_hstop (MSBs)	auxiliary display signal horizontal stop (higher 2 of 10 bits)
	4 to 5	ads_vstart (MSBs)	auxiliary display signal vertical start (higher 2 of 10 bits)
	6 to 7	ads_vstop (MSBs)	auxiliary display signal vertical stop (higher 2 of 10 bits)
0230	0 to 7	hd_hstart	horizontal deflection pulse start; 4 pixels resolution
0231	0 to 7	hd_hstop	horizontal deflection pulse stop; 4 pixels resolution
0234	0 to 7	reo_hstart	read enable output window horizontal start (lower 8 of 10 bits)
0235	0 to 7	reo_hstop	read enable output window horizontal stop (lower 8 of 10 bits)
0238	0 to 1	reo_hstart (MSBs)	read enable output window horizontal start (higher 2 of 10 bits)
	2 to 3	reo_hstop (MSBs)	read enable output window horizontal stop (higher 2 of 10 bits)
	4 to 7	–	reserved
023A	0 to 7	fl	display field length (lower 8 of 11 bits)

Sample rate converter with embedded high quality dynamic noise reduction and expansion port

SAA4979H

HOST ADDRESS (HEX)	BIT	NAME	DESCRIPTION
023B	0 to 2	fl (MSBs)	display field length (higher 3 of 11 bits)
	3 to 7	–	reserved
023C	0 to 7	hp1	frame synchronization pulse position; 4 pixels resolution
023D	0 to 7	dsplock_vstart	display locking window vertical start (lower 8 of 10 bits)
023E	0 to 7	dsplock_vstop	display locking window vertical stop (lower 8 of 10 bits)
023F	0 to 1	dsplock_vstart (MSBs)	display locking window vertical start (higher 2 of 10 bits)
	2 to 3	dsplock_vstop (MSBs)	display locking window vertical stop (higher 2 of 10 bits)
	4 to 7	–	reserved
Host address 0287H to 028DH (panoramic zoom)			
0287	0 to 7	c2	compression or expansion non-linearity value
0288	0 to 7	c0	linear compression or expansion value (lower 8 of 9 bits)
0289	0 to 7	hshift (LSBs)	horizontal pixel shift (lower 8 of 16 bits)
028A	0 to 7	hshift (MSBs)	horizontal pixel shift (higher 8 of 16 bits)
028B	0 to 7	nrln	number of lines per field (lower 8 of 10 bits)
028C	0 to 7	nrpx_div4	number of pixels per line divided-by-4
028D	0	transparent_mode	bypass panoramic zoom: 0 = panoramic zoom active, 1 = bypass
	1	c0 (MSB)	linear compression or expansion value (MSB)
	2 to 3	nrln (MSBs)	number of lines per field (higher 2 of 10 bits)
	4 to 7	–	reserved
Host address 0280H to 0284H and 0290H (mid-end control)			
0280	0 to 7	mid_hstart	bandwidth detection window horizontal start (lower 8 of 10 bits)
0281	0 to 7	bw_hstop	bandwidth detection window horizontal stop (lower 8 of 10 bits)
0282	0 to 7	bw_vstart	bandwidth detection window vertical start (lower 8 of 10 bits)
0283	0 to 7	bw_vstop	bandwidth detection window vertical stop (lower 8 of 10 bits)
0284	0 to 1	bw_hstart (MSBs)	bandwidth detection window horizontal start (higher 2 of 10 bits)
	2 to 3	bw_hstop (MSBs)	bandwidth detection window horizontal stop (higher 2 of 10 bits)
	4 to 5	bw_vstart (MSBs)	bandwidth detection window vertical start (higher 2 of 10 bits)
	6 to 7	bw_vstop (MSBs)	bandwidth detection window vertical stop (higher 2 of 10 bits)
0290	0	bypass_downsampling	bypass downsampling: 0 = downsampling active, 1 = bypass
	1	mid_uv_inv	inverts UVO output signals: 0 = no inversion, 1 = inversion
	2	bypass_FSRC	bypass Fixed Sample Rate Converter (FSRC): 0 = FSRC active, 1 = bypass
	3 to 7	–	reserved
Host address 0298H to 029FH (back-end control)			
0298	0 to 7	be_hstart	back-end window horizontal start (lower 8 of 10 bits)
0299	0 to 7	be_hstop	back-end window horizontal stop (lower 8 of 10 bits)
029A	0 to 7	be_vstart	back-end window vertical start (lower 8 of 10 bits)
029B	0 to 7	be_vstop	back-end window vertical stop (lower 8 of 10 bits)

Sample rate converter with embedded high quality dynamic noise reduction and expansion port

SAA4979H

HOST ADDRESS (HEX)	BIT	NAME	DESCRIPTION
029C	0 to 1	be_hstart (MSBs)	back-end window horizontal start (higher 2 of 10 bits)
	2 to 3	be_hstop (MSBs)	back-end window horizontal stop (higher 2 of 10 bits)
	4 to 5	be_vstart (MSBs)	back-end window vertical start (higher 2 of 10 bits)
	6 to 7	be_vstop (MSBs)	back-end window vertical stop (higher 2 of 10 bits)
029D	0 to 7	exp_hstart	expansion port input window: horizontal start (lower 8 of 10 bits)
029E	0 to 1	exp_hstart (MSBs)	expansion port input window: horizontal start (higher 2 of 10 bits)
	2 to 7	–	reserved
029F	0	bypass_upsampling	bypass upsampling: 0 = upsampling active, 1 = bypass
	1	extern_device	external device multiplexer: 0 = internal, 1 = data from external device
	2 to 7	–	reserved
Host address 02A0H to 02A6H (dynamic horizontal smart peaking)			
02A0	0 to 7	steepness_vstart	steepness detection window vertical start; 4 lines resolution
02A1	0 to 7	steepness_vstop	steepness detection window vertical stop; 4 lines resolution
02A2	0 to 7	steepness_hstart	steepness detection window horizontal start; 4 pixels resolution
02A3	0 to 7	steepness_hstop	steepness detection window horizontal stop; 4 pixels resolution
02A4	0 to 2	pk_alpha	peaking α : $\frac{1}{16}$ (0, 1, 2, 3, 4, 5, 6, 8)
	3 to 5	pk_beta	peaking β : $\frac{1}{16}$ (0, 1, 2, 3, 4, 5, 6, 8)
	6 and 7	–	reserved
02A5	0 to 2	pk_tau	peaking τ : $\frac{1}{16}$ (0, 1, 2, 3, 4, 5, 6, 8)
	3 and 4	pk_delta	peaking amplitude dependent attenuation: $\frac{1}{4}$ (0, 1, 2, 4)
	5 and 6	pk_neggain	peaking attenuation of undershoots: $\frac{1}{4}$ (0, 1, 2, 4)
	7	–	reserved
02A6	0 to 3	pk_corthr	peaking coring threshold: 0, ± 4 , ± 8 , ± 12 , ± 16 to ± 60 LSB
	4	output_range	output range: output range = 0: 9 bits for the nominal output signal, black level: 288 and white level: 727; output range = 1: 10 bits for the nominal output signal, black level: 64 and white level: 940
	5 to 7	–	reserved
Host address 02A8H and 02A9H (DCTI)			
02A8	0 to 2	dcti_gain	DCTI gain: 0, 1, 2, 3, 4, 5, 6 and 7
	3 to 6	dcti_threshold	DCTI threshold: 0, 1 to 15
	7	dcti_ddx_sel	DCTI selection of first differentiating filter; see Fig.9
02A9	0 and 1	dcti_limit	DCTI limit for pixel shift range: 0, 1, 2 and 3
	2	dcti_separate	DCTI separate processing of U and V signals; 0 = off; 1 = on
	3	dcti_protection	DCTI over the hill protection; 0 = off; 1 = on
	4	dcti_filteron	DCTI post-filter; 0 = off; 1 = on
	5	dcti_superhill	DCTI super hill mode; 0 = off; 1 = on
	6 and 7	–	reserved

Sample rate converter with embedded high quality
dynamic noise reduction and expansion port

SAA4979H

HOST ADDRESS (HEX)	BIT	NAME	DESCRIPTION
Host address 02B0H to 02BBH and 02AAH (post processing)			
02B0	0 to 3	sidepanel_u	side panel colour U value (4 MSB)
	4 to 7	sidepanel_v	side panel colour V value (4 MSB)
02B1	0 to 7	sidepanel_y	side panel luminance value (8 MSB)
02B2	0 to 7	sidepanel_hstart	side panel start position (higher 8 of 10 bits)
02B3	0 to 7	sidepanel_hstop	side panel stop position (higher 8 of 10 bits)
02B4	0 to 3	y_delay	Y delay relative to UV channel, in clock cycles: -8, -7, -6, -5, -4, -3, -2, -1, 0, 1, 2, 3, 4, 5, 6, and 7
	4	uv_inv_out	inverts UV output signals: 0 = no inversion, 1 = inversion
	5	y_dac_current	gain Y digital-to-analog converter: 0 = 2 μ A/bit (range 1), 1 = 4 μ A/bit (range 0); see Fig.6
	6 to 7	–	reserved
02B5	0 to 7	bln_hstart	blanking window horizontal start position (lower 8 of 10 bits)
02B6	0 to 7	bln_hstop	blanking window horizontal stop position (lower 8 of 10 bits)
02B7	0 to 7	bln_vstart	blanking window vertical start position (lower 8 of 10 bits)
02B8	0 to 7	bln_vstop	blanking window vertical stop position (lower 8 of 10 bits)
02B9	0 to 1	bln_hstart (MSBs)	blanking window horizontal start position (higher 2 of 10 bits)
	2 to 3	bln_hstop (MSBs)	blanking window horizontal stop position (higher 2 of 10 bits)
	4 to 5	bln_vstart (MSBs)	blanking window vertical start position (higher 2 of 10 bits)
	6 to 7	bln_vstop (MSBs)	blanking window vertical stop position (higher 2 of 10 bits)
02BA	0 to 1	nlp_u	non-linear phase filter settings μ : (0, $\frac{1}{4}$, $\frac{1}{2}$, $\frac{1}{2}$)
	2 to 3	nlp_l	non-linear phase filter settings λ : (0, $\frac{1}{8}$, $\frac{2}{8}$, $\frac{3}{8}$)
	4 to 5	sidepanel_hstart (LSBs)	side panel start position (lower 2 of 10 bits)
	6 to 7	sidepanel_hstop (LSBs)	side panel stop position (lower 2 of 10 bits)
02BB	0 to 7	PIP_frame_hstart	PIP frame: horizontal start position (lower 8 of 10 bits)
02BC	0 to 7	PIP_frame_hstop	PIP frame: horizontal stop position (lower 8 of 10 bits)
02BD	0 to 7	PIP_frame_vstart	PIP frame: vertical start position (lower 8 of 10 bits)
02BE	0 to 7	PIP_frame_vstop	PIP frame: vertical stop position (lower 8 of 10 bits)
02BF	0 to 1	PIP_frame_vstart (MSBs)	PIP frame: vertical start position (higher 2 of 10 bits)
	2 to 3	PIP_frame_vstop (MSBs)	PIP frame: vertical stop position (higher 2 of 10 bits)
	4 to 5	PIP_frame_hstart (MSBs)	PIP frame: horizontal start position (higher 2 of 10 bits)
	6 to 7	PIP_frame_hstop (MSBs)	PIP frame: horizontal stop position (higher 2 of 10 bits)
02AA	0 to 3	PIP_frame_width (MSBs)	PIP horizontal frame width (0 to 15 pixel)
	4 to 7	PIP_frame_height (MSBs)	PIP vertical frame width (0 to 15 pixel)

Sample rate converter with embedded high quality dynamic noise reduction and expansion port

SAA4979H

HOST ADDRESS (HEX)	BIT	NAME	DESCRIPTION
Host address 0300H to 0305H (PLL)			
0300	0 to 2	PLL_cd_value	damping factor
	3 to 7	PLL_ck_value	time constant
0301	0 to 1	–	reserved
	2 to 4	PLL_idto (MSBs)	signed increment offset of DTO (MSBs)
	5	0	to be cleared
	6	PLL_off_hif	freeze frequency
	7	PLL_open	disable outer loop: 0 = outer loop closed, 1 = outer loop open
0302	0 to 7	PLL_idto2	signed increment offset of DTO (higher byte)
0303	0 to 7	PLL_idto1	signed increment offset of DTO (lower byte)
0304	0	PLL_freq_shift	operating frequency shift: 0 = no shift, 1 = frequency shift of 8%
	1	PLL_limiter_off	PLL frequency limiter of outer loop: 0 = limiter on, 1 = limiter off
	2 to 7	–	reserved
0305	0 to 2	PLL_cd_adapt	damping factor in adaptive mode
	3 to 7	PLL_ck_adapt	time constant in adaptive mode

Table 8 Read register at 1f_H

HOST ADDRESS (HEX)	BIT	NAME	DESCRIPTION
Host address 0142H and 0143H (system control)			
0142	0 to 7	fieldinf	result of field length measurement (lower 8 of 10 bits)
0143	0 to 1	filedinf (MSBs)	result of field length measurement (higher 2 of 10 bits)
	2	frg	field recognition of incoming source
	3 to 7	–	reserved
Host address 01C0H to 01C4H (noise estimator)			
01C0	0 to 3	nest	noise estimation result
	4 to 7	–	reserved
01C1	0 to 7	nest_filt	noise estimation value filtered
01C2	0 to 7	detail_cnt_h	output of detail counter, higher byte
01C3	0 to 7	detail_cnt_l	output of detail counter, lower byte
01C4	0 to 7	grey_cnt	output of grey counter
Host address 01CAH and 01CBH (black bar detection)			
01CA	0 to 6	bbd_1st_videoline	line number of first video line
	7	bbd_last_videoline (MSB)	line number of last video line (MSB)
01CB	0 to 7	bbd_last_videoline	line number of last video line

Sample rate converter with embedded high quality dynamic noise reduction and expansion port

SAA4979H

Table 9 Read register at 2f_H

HOST ADDRESS (HEX)	BIT	NAME	DESCRIPTION
Host address 0242H (system control)			
0242	0 to 3	dspflds	number of display fields – 1
	4	dsp_unlock	display unlock: 0 = normal operation, 1 = vertical display timing unlocked
	5 to 7	–	reserved
Host address 02C8H (UV bandwidth detection)			
02C8	0 to 7	UV_bw_detect	result of UV bandwidth detection (unsigned value)
Host address 02D0H (dynamic peaking)			
02D0	0 to 7	steepness_max	result of steepness detection (unsigned value)

8.2 Special Function Registers (SFRs)**Table 10** SNERT-bus control

SFR ADDRESS (HEX)	BIT	READ/WRITE	NAME	DESCRIPTION
Special function register 9AH (SNCON); reset value: 00H				
9A	0	read	TRM	SNERT transmit busy flag: TRM is set to logic 1 after SFR 9CH (SNWDA) is accessed, after a transmission TRM is set to logic 0
	1	read and write	REC	SNERT receive busy flag: if REC is set to logic 1 the contents of SFR 9BH (SNADD) is transmitted, after reception is completed REC is set to logic 0
	2 to 6	–	–	reserved
	7	read and write	MB2	SNERT baud rate: 0 = 1 MHz, 1 = 2 MHz
Special function register 9BH (SNADD)				
9B	0 to 7	write	SNADD	SNERT address
Special function register 9CH (SNWDA)				
9C	0 to 7	write	SNWDA	SNERT data to be transmitted
Special function register 9DH (SNRDA)				
9D	0 to 7	read	SNRDA	data received from SNERT-bus

Sample rate converter with embedded high quality dynamic noise reduction and expansion port

SAA4979H

Table 11 Power control

SFR ADDRESS (HEX)	BIT	READ/WRITE	NAME	DESCRIPTION
Special function register 87H (PCON); reset value: 00H				
87	0	read and write	IDL	Idle mode bit: 0 = normal operation, 1 = Idle mode operation
	1	read and write	PD	Power-down bit: 0 = normal operation, 1 = Power-down mode
	2 to 3	–	–	reserved
	4	read and write	WLE	Watchdog load enable: 0 = loading of Watchdog timer disabled, 1 = loading of Watchdog timer enabled
			EW	enable Watchdog: 0 = Watchdog disabled, 1 = Watchdog enabled; once this bit is set only a synchronous reset can clear it
	5	read and write	RFI	radio frequency interference bit: disables toggling of internal ALE signal during on-chip program access if set to logic 1
	6	read and write	ARD	auxiliary RAM disable: setting this bit will force MOVX instructions to access off-chip memory instead of AUXRAM
	7	–	–	reserved

9 LIMITING VALUES

In accordance with the Absolute Maximum Rating System (IEC 60134).

SYMBOL	PARAMETER	CONDITIONS	MIN.	MAX.	UNIT
V _{DDD}	digital supply voltage		-0.5	+4.0	V
V _{DDA}	analog supply voltage		-0.5	+4.0	V
V _{DDI}	internal I/O supply voltage		-0.5	+4.0	V
V _{DDO}	I/O supply voltage	V _{DDD} = 3.3 V	-0.5	+3.8	V
V _{DDP}	supply voltage for protection circuits		-0.5	+5.5	V
V _I	input voltage for all digital input pins	V _{DDP} = 5 V	-0.5	+5.5	V
		V _{DDP} = 3.3 V	-0.5	+3.8	V
V _I	input voltage for all digital I/O pins		-0.5	+3.8	V
I _{DD(tot)}	total supply current		–	300	mA
I _O	short circuit output current		–	30	mA
P _{tot}	total power dissipation		–	1.2	W
T _{stg}	storage temperature		-25	+150	°C
T _j	junction temperature		0	+125	°C
T _{amb}	ambient temperature		0	+70	°C
V _{es}	electrostatic handling voltage	note 1	-200	+200	V
		note 2	-2000	+2000	V

Notes

- Machine model class B, equivalent to discharging a 200 pF capacitor through a 0 Ω series resistor (0 Ω is actually 0.75 μH + 10 Ω).
- Human body model class B, equivalent to discharging a 100 pF capacitor through a 1500 Ω series resistor.

Sample rate converter with embedded high quality dynamic noise reduction and expansion port

SAA4979H

10 THERMAL CHARACTERISTICS

SYMBOL	PARAMETER	CONDITIONS	VALUE	UNIT
$R_{th(j-a)}$	thermal resistance from junction to ambient	in free air	45	K/W

11 CHARACTERISTICS

$V_{DDD} = 3.0$ to 3.6 V; $V_{DDO} = 3.0$ to 3.6 V; $V_{DDA} = 3.15$ to 3.45 V; $T_{amb} = 0$ to 70 °C; unless otherwise specified.

SYMBOL	PARAMETER	CONDITIONS	MIN.	TYP.	MAX.	UNIT
Supplies						
V_{DDD}	digital supply voltage		3.0	3.3	3.6	V
V_{DDA}	analog supply voltage		3.15	3.30	3.45	V
V_{DDI}	internal I/O supply voltage		3.0	3.3	3.6	V
V_{DDO}	I/O supply voltage		3.0	3.3	3.6	V
V_{DDP}	protection supply voltage		3.0	5.0	5.5	V
I_{DDD}	digital supply current		–	120	160	mA
I_{DDA}	analog supply current		–	40	50	mA
I_{DDI}	internal I/O supply current		–	0	2	mA
I_{DDO}	I/O supply current		–	10	40	mA
I_{DDP}	protection supply current		–	0	1	mA
Output transfer function (sample rate 32 MHz/10 bits)						
INL	integral non linearity		–2	–	+2	LSB
DNL	differential non linearity		–1	–	+1	LSB
Luminance output signal: pin YOUT						
$V_{o(p-p)}$	Y output level (peak-to-peak value)	output range = 0: nominal amplitude digital 288 to 727; output range = 1: nominal amplitude digital 64 to 940	0.94	1.00	1.06	V
$V_{o(black)}$	Y black level (voltage at 288)	output range = 0	0.837	0.891	0.944	V
	Y black level (voltage at 64)	output range = 1	0.836	0.889	0.942	V
R_o	output resistance		–	75	85	Ω
C_L	capacitive load		–	–	25	pF
S/N	signal-to-noise ratio	nominal amplitude; 0 to 10 MHz	46	–	–	dB
Colour difference output signals: pins UOUT and VOUT						
$V_{o(p-p)}$	U output level (peak-to-peak value)	for saturated colour bar with 75% of maximum amplitude	1.25	1.33	1.41	V
	V output level (peak-to-peak value)	for saturated colour bar with 75% of maximum amplitude	0.99	1.05	1.11	V

Sample rate converter with embedded high quality dynamic noise reduction and expansion port

SAA4979H

SYMBOL	PARAMETER	CONDITIONS	MIN.	TYP.	MAX.	UNIT
$V_{O(\text{colourless})}$	U colourless level (voltage at 512)		1.32	1.40	1.48	V
	V colourless level (voltage at 512)		1.32	1.40	1.48	V
$G_{D(U-V)}$	gain matching U to V		–	1	3	%
R_o	output resistance		–	75	85	Ω
C_L	capacitive load		–	–	25	pF
S/N	signal-to-noise ratio	nominal amplitude; 0 to 10 MHz	46	–	–	dB
Digital output signals: pins OIE2, RSTR2 and RE2						
V_{OH}	HIGH-level output voltage	$I_{OH} = -0.5 \text{ mA}$	2.4	–	–	V
V_{OL}	LOW-level output voltage	$I_{OL} = 0.5 \text{ mA}$	–	–	0.4	V
Digital output signals: all pins except OIE2, RSTR2 and RE2						
V_{OH}	HIGH-level output voltage	$I_{OH} = -2.0 \text{ mA}$	2.4	–	–	V
V_{OL}	LOW-level output voltage	$I_{OL} = 2.0 \text{ mA}$	–	–	0.4	V
Digital input signals: pins DI1, DI2, LLC1, LLC2, RSTW2, TDI, TMS, TCK, BCE and TRST						
V_{IH}	HIGH-level input voltage		2	–	$V_{DDP} + 0.3$	V
V_{IL}	LOW-level input voltage		–	–	0.8	V
I_{LI}	input leakage current		–	–	10	μA
Digital input signals: pins UVI, YI, REI and RST						
V_{IH}	HIGH-level input voltage		2.0	–	5.5	V
V_{IL}	LOW-level input voltage		–	–	0.8	V
I_{IH}	HIGH-level input current		–	–	100	μA
I_{IL}	LOW-level input current		–	–	10	μA
Digital input signal: pin CLKEXT						
V_{IH}	HIGH-level input voltage		2.0	–	5.5	V
V_{IL}	LOW-level input voltage		–	–	0.8	V
I_{LI}	input leakage current		–	–	10	μA
Digital input/output signals: pins SNRST and P1.2 to P1.5						
V_{OH}	HIGH-level output voltage	$I_{OH} = -2.0 \text{ mA}$	2.4	–	–	V
V_{OL}	LOW-level output voltage	$I_{OL} = 2.0 \text{ mA}$	0	–	0.4	V
V_{IH}	HIGH-level input voltage		2.0	–	3.8	V
V_{IL}	LOW-level input voltage		0	–	0.8	V
I_{IH}	HIGH-level input current		–	–	10	μA
I_{IL}	LOW-level input current		–	–	100	μA
Digital input/output signal: pin SNDA						
V_{OH}	HIGH-level output voltage	$I_{OH} = -2.0 \text{ mA}$	2.4	–	–	V
V_{OL}	LOW-level output voltage	$I_{OL} = 2.0 \text{ mA}$	0	–	0.4	V
V_{IH}	HIGH-level input voltage		2.0	–	5.5	V
V_{IL}	LOW-level input voltage		0	–	0.8	V
I_{LI}	input leakage current		–	–	10	μA

Sample rate converter with embedded high quality
dynamic noise reduction and expansion port

SAA4979H

SYMBOL	PARAMETER	CONDITIONS	MIN.	TYP.	MAX.	UNIT
Data output timing: pins OIE2, RSTR2 and RE2 ($C_L = 15$ pF); timing referenced to LLC1						
$t_{d(o)}$	output delay time	see Fig.8	–	–	26	ns
$t_{h(o)}$	output hold time	see Fig.8	4	–	–	ns
Data output timing: pins YO, UVO, IE, REO, ADS, HD and VD ($C_L = 15$ pF); timing referenced to CLK32						
$t_{d(o)}$	output delay time	see Fig.8	–	–	20	ns
$t_{h(o)}$	output hold time	see Fig.8	3	–	–	ns
Data input timing: pins RSTW2, DI1 and DI2; timing referenced to LLC1						
$t_{su(i)}$	input set-up time	see Fig.8	4	–	–	ns
$t_{h(i)}$	input hold time	see Fig.8	3	–	–	ns
Data input timing: pins YI, UVI and REI; timing referenced to CLK32						
$t_{su(i)}$	input set-up time	see Fig.8	4	–	–	ns
$t_{h(i)}$	input hold time	see Fig.8	3	–	–	ns
Clock input timing: pins LLC1 and LLC2						
T_{cy}	cycle time		34	37	40	ns
δ_{clk}	clock duty factor		40	50	60	%
t_r	clock rise time	see Fig.8	–	–	5	ns
t_f	clock fall time	see Fig.8	–	–	5	ns
Clock input timing: pin CLKEXT						
T_{cy}	cycle time		29.00	31.25	34.00	ns
δ_{clk}	clock duty factor		40	50	60	%
t_r	clock rise time	see Fig.8	–	–	5	ns
t_f	clock fall time	see Fig.8	–	–	5	ns
Clock output timing: pin CLK32 ($C_L = 25$ pF)						
T_{cy}	cycle time		26.00	31.25	38.00	ns
δ_{clk}	clock duty factor		45	50	55	%
t_r	output rise time	see Fig.8	–	–	4	ns
t_f	output fall time	see Fig.8	–	–	4	ns
PLL function (base frequency 32 MHz)						
$\sigma_{line-line}$	sigma value of line-to-line jitter	locked to stable H signal	–	0.4	1.0	ns
I²C-bus signals: pins SDA and SCL; note 1						
V_{IH}	HIGH-level input voltage		$0.7V_{DDO}$	–	5.5	V
V_{IL}	LOW-level input voltage		–	–	$0.3V_{DDO}$	V
V_{hys}	hysteresis voltage		$0.05V_{DDO}$	–	–	V
V_{OL}	LOW-level output voltage	$I_{OL} = 3.0$ mA	–	–	0.4	V
I_{LI}	input leakage current		–	–	10	μ A
f_{SCL}	SCL clock frequency		–	–	400	kHz
t_r	rise time of SDA and SCL		–	–	0.3	μ s
t_f	fall time of SDA and SCL		–	–	0.3	μ s

Sample rate converter with embedded high quality dynamic noise reduction and expansion port

SAA4979H

SYMBOL	PARAMETER	CONDITIONS	MIN.	TYP.	MAX.	UNIT
$t_{HD;STA}$	hold time START condition		0.6	–	–	μs
$t_{HD;DAT}$	data hold time		0	–	0.9	μs
t_{LOW}	SCL LOW time		1.3	–	–	μs
t_{HIGH}	SCL HIGH time		0.6	–	–	μs
$t_{SU;DAT}$	data set-up time		100	–	–	ns
$t_{SU;STA}$	set-up time repeated START		0.6	–	–	μs
$t_{SU;STO}$	set-up time STOP condition		0.6	–	–	μs
t_{BUF}	bus free time between a STOP and START condition		1.3	–	–	μs
SNERT-bus timing (valid for both 1 and 2 Mbaud): pins SNDA and SNCL; note 2						
$t_{su(i)}$	input set-up time		80	–	–	ns
$t_{h(i)}$	input hold time		0	–	–	ns
$t_{h(o)}$	output hold time		50	–	–	ns
$t_{su(o)}$	output set-up time		260	–	–	ns
$t_{cy(SNCL)}$	SNCL cycle time		500	–	1000	ns
t_{SNRSTH}	SNRST pulse HIGH time		500	–	–	ns
$t_d(SNRST-DAT)$	delay SNRST pulse to data		200	–	–	ns

Notes

1. The AC characteristics are in accordance with the I²C-bus specification for fast mode (clock frequency maximum 400 kHz). Information about the I²C-bus can be found in the brochure "I²C-bus and how to use it" (order number 9398 393 40011).
2. More information about the SNERT-bus protocol can be found in Application Note "The SNERT-bus specification" (AN95127).

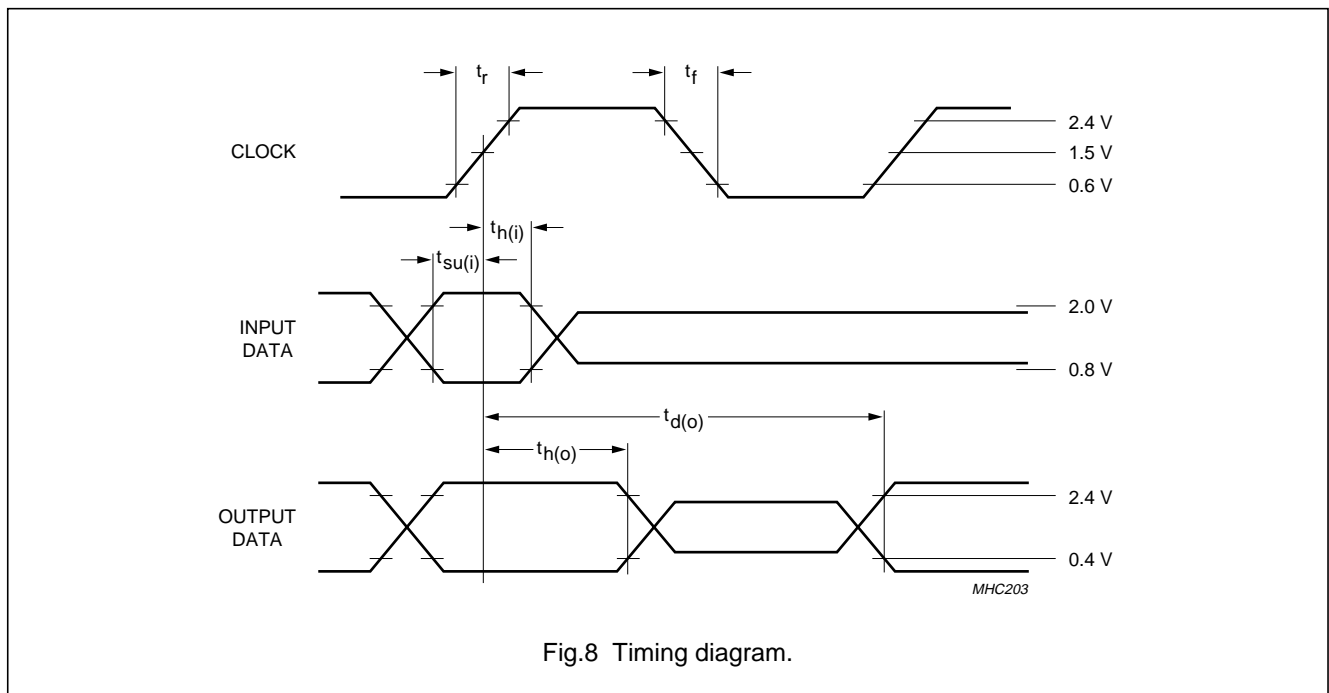
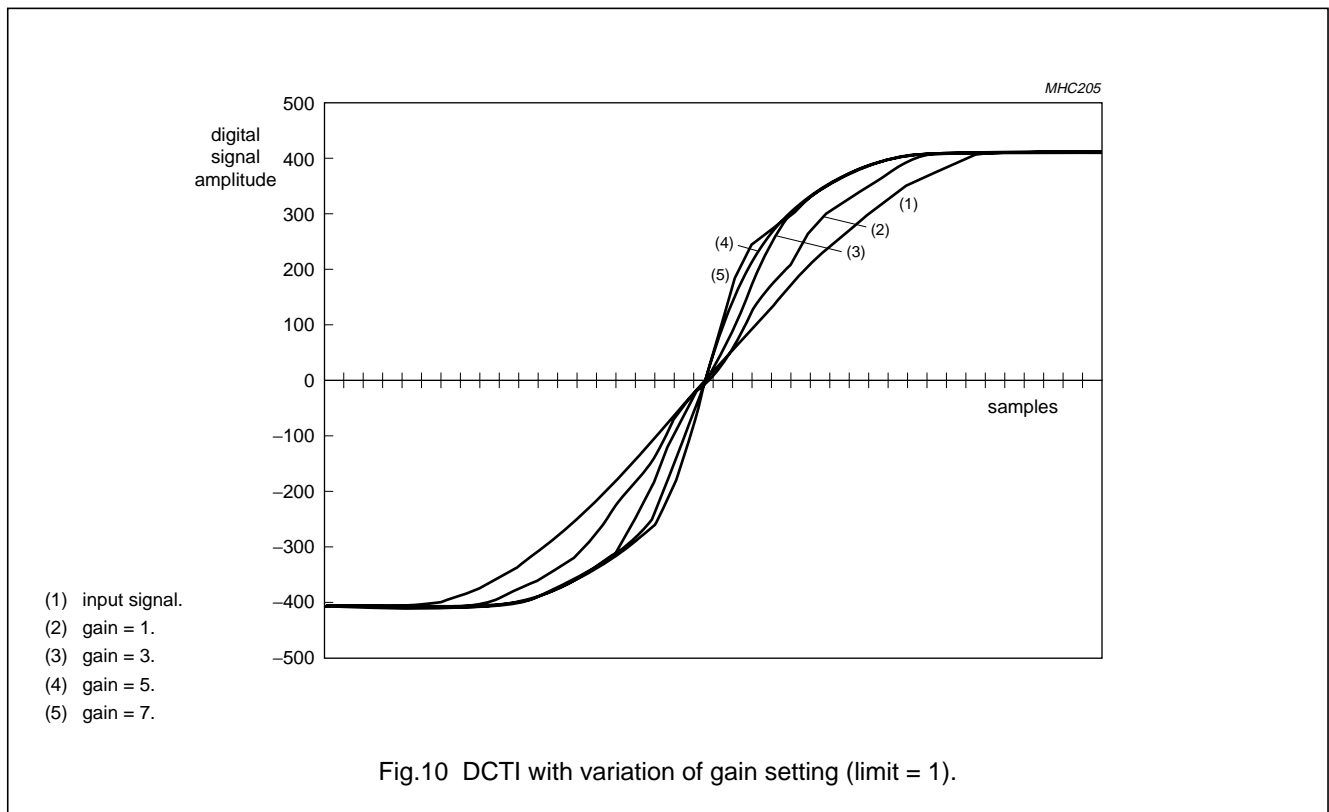
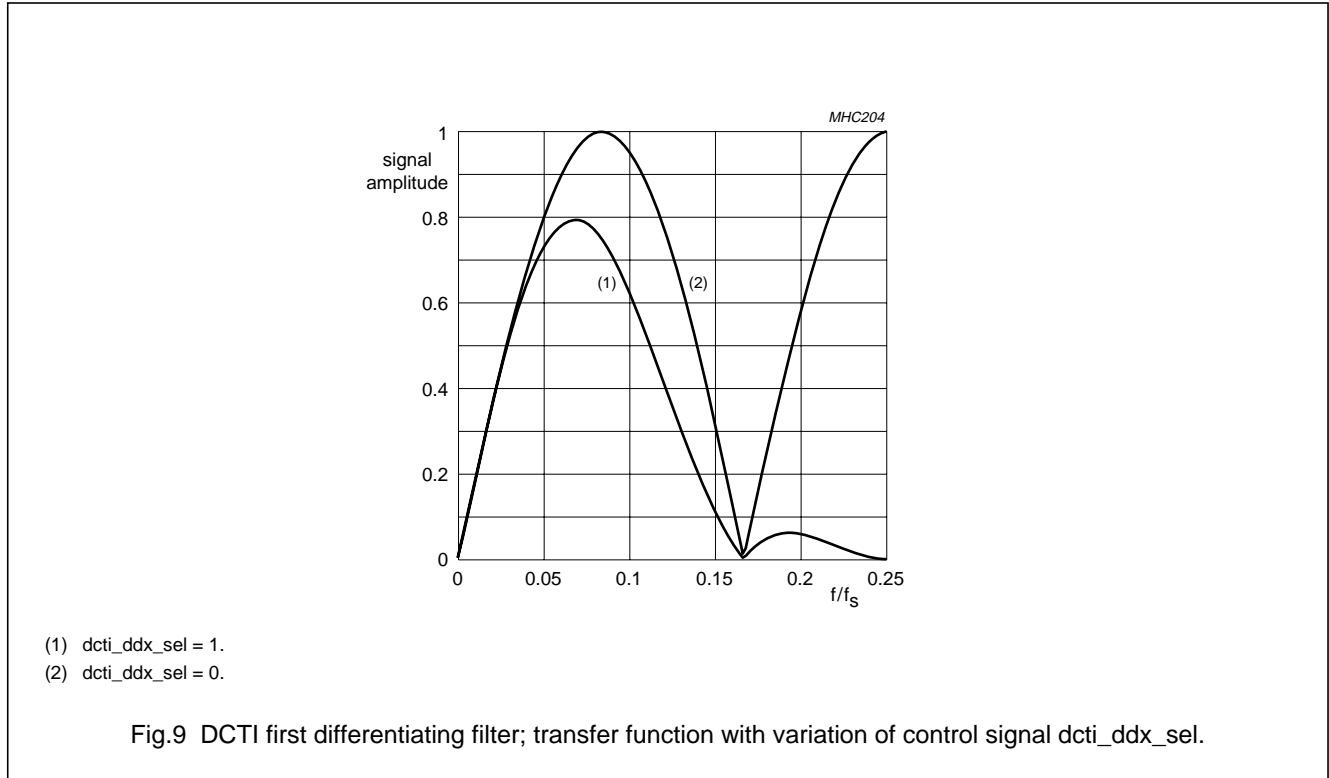

Fig.8 Timing diagram.

Sample rate converter with embedded high quality dynamic noise reduction and expansion port

SAA4979H

12 TRANSFER FUNCTIONS



Sample rate converter with embedded high quality dynamic noise reduction and expansion port

SAA4979H

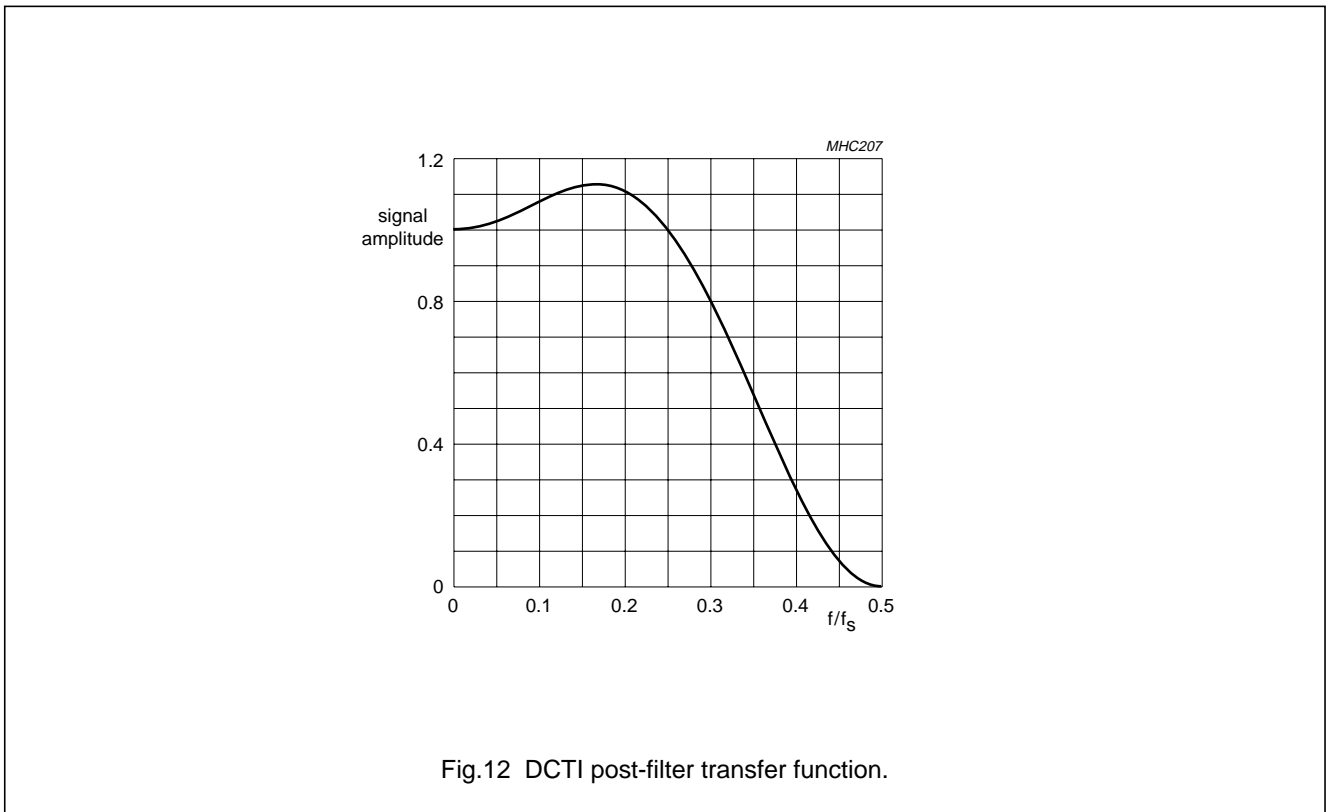
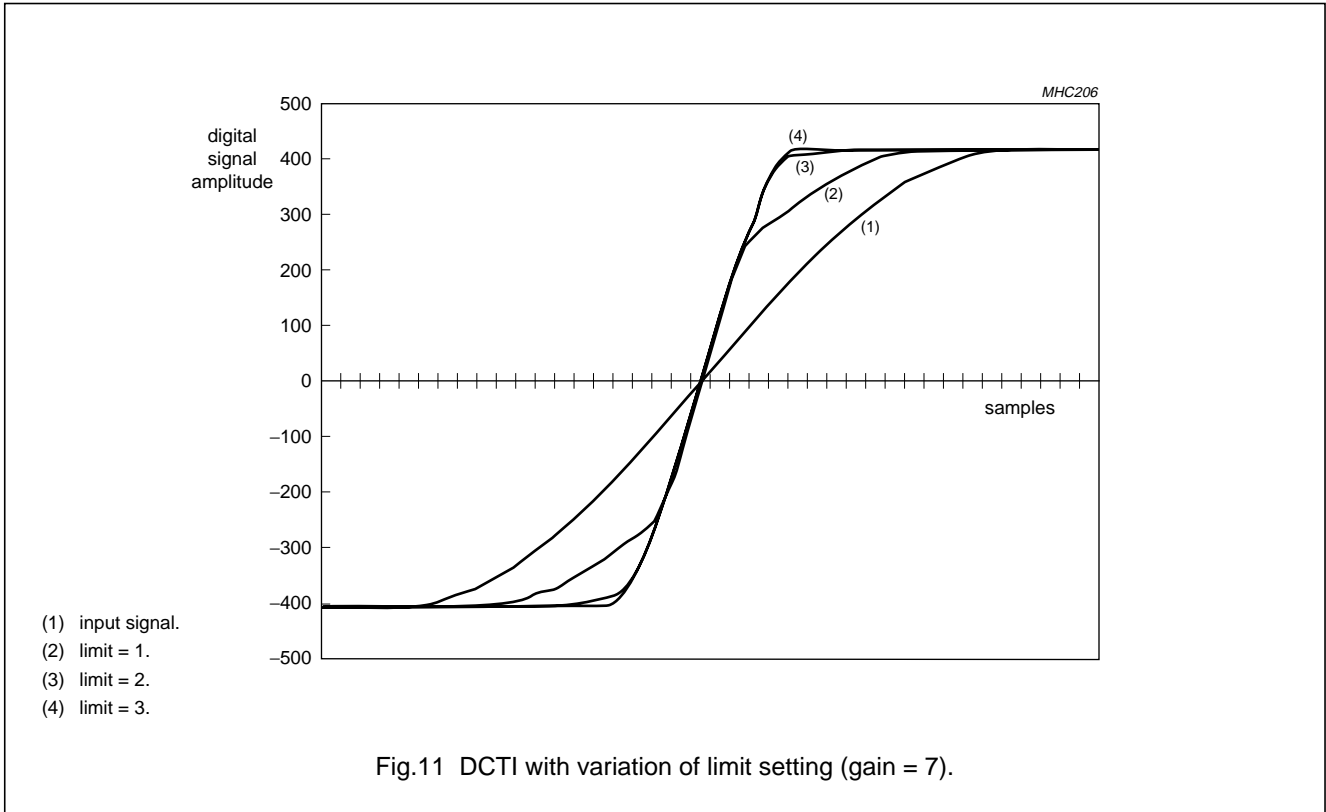

Sample rate converter with embedded high quality dynamic noise reduction and expansion port

SAA4979H

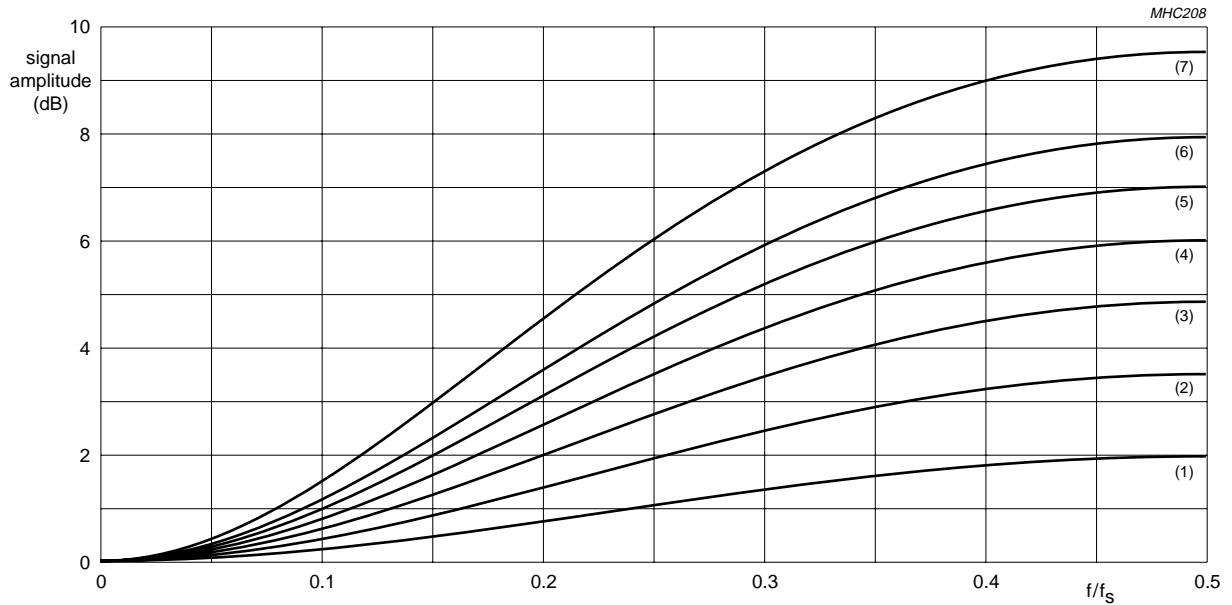

- (1) $\beta = 1/16$.
- (2) $\beta = 2/16$.
- (3) $\beta = 3/16$.
- (4) $\beta = 4/16$.
- (5) $\beta = 5/16$.
- (6) $\beta = 6/16$.
- (7) $\beta = 8/16$.

Fig.13 Transfer function of the peaking high-pass filter with variation of β ($\alpha = 0$; $\tau = 0$).

Sample rate converter with embedded high quality dynamic noise reduction and expansion port

SAA4979H

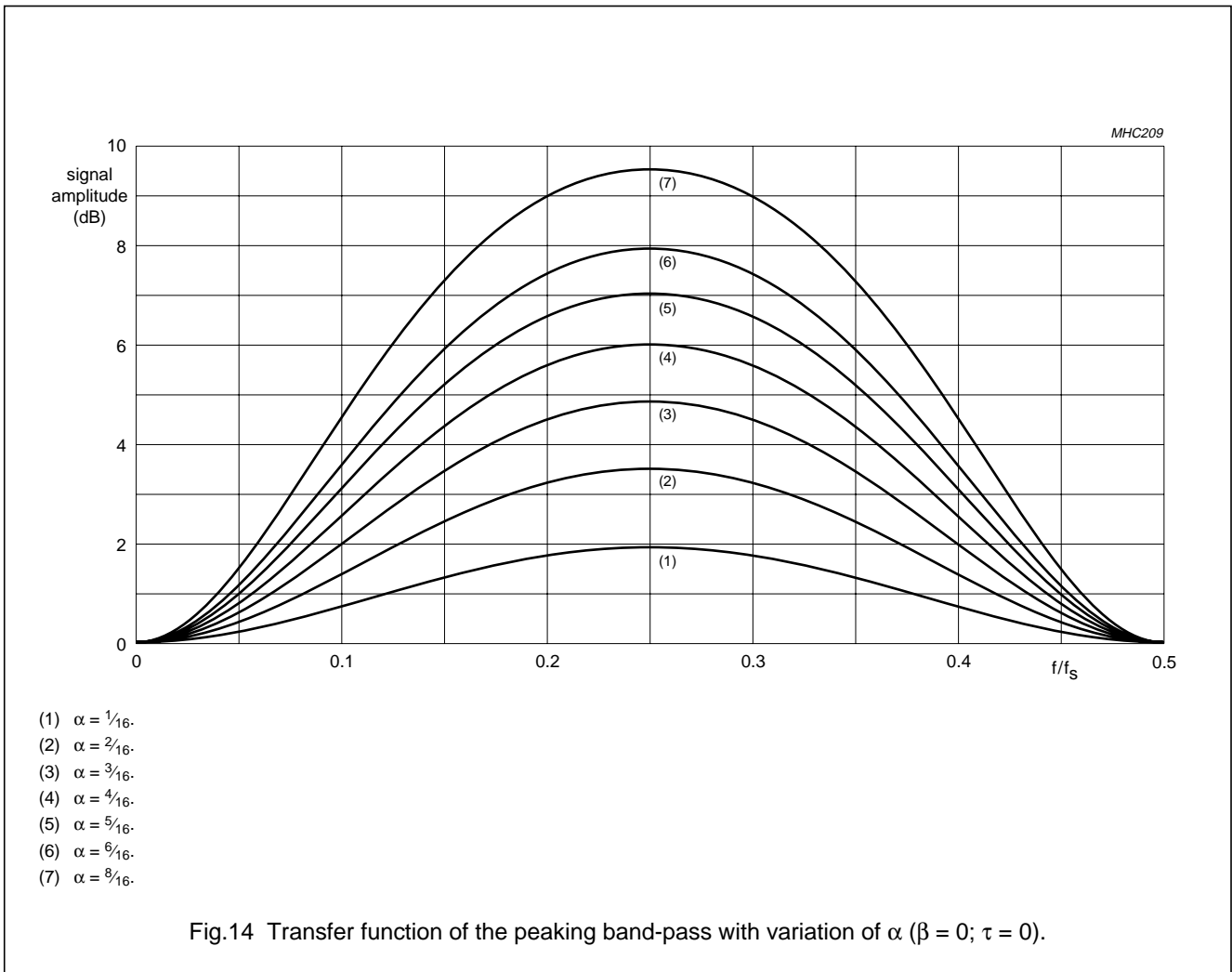

Sample rate converter with embedded high quality dynamic noise reduction and expansion port

SAA4979H

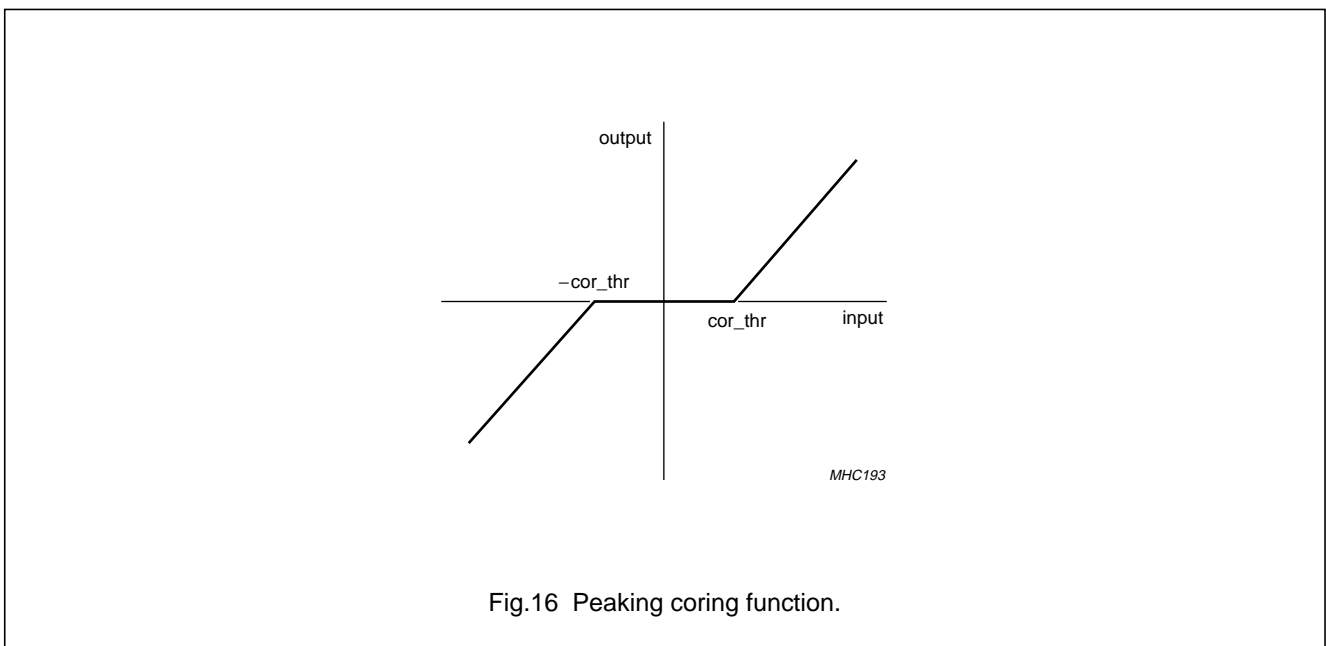
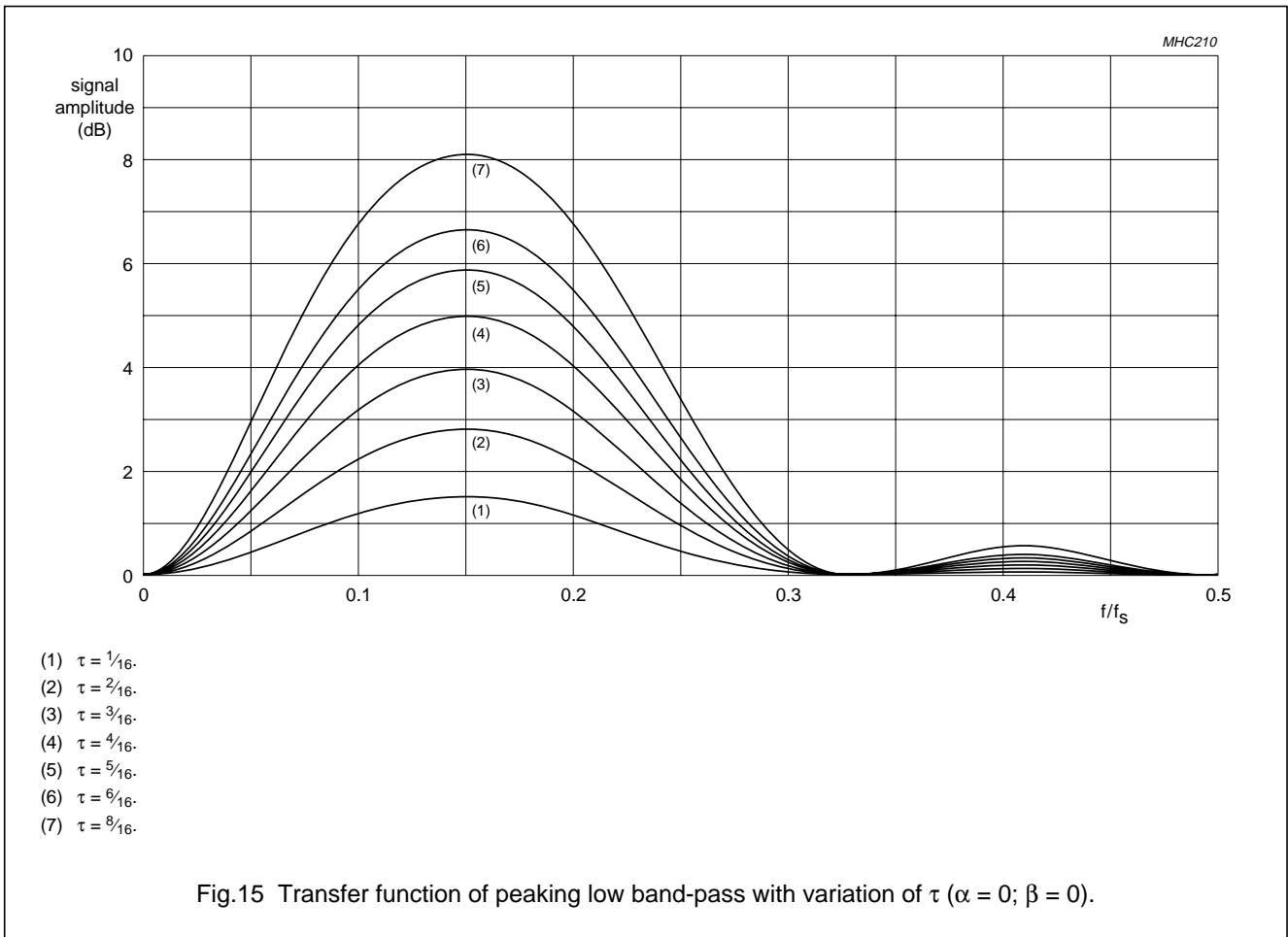

**Sample rate converter with embedded high quality
dynamic noise reduction and expansion port**

SAA4979H**13 APPLICATION INFORMATION**

The SAA4979H supports different scan-rate upconversion concepts. The simple one is illustrated in Fig.17. In this application no further components are needed for a 100 Hz conversion based on a field repetition algorithm (AABB mode).

The system can be upgraded by a vector based motion estimation and compensation function. In this case the SAA4992H together with two field memories (SAA4955) are needed (see Figs 18 and 19 respectively).

In addition the SAA4979H supports field based and frame based picture-in-picture applications. To realize the full performance frame based PIP function a second video decoder (SAA7118) and two additional field memories are required (see Fig.20).

Sample rate converter with embedded high quality dynamic noise reduction and expansion port

SAA4979H

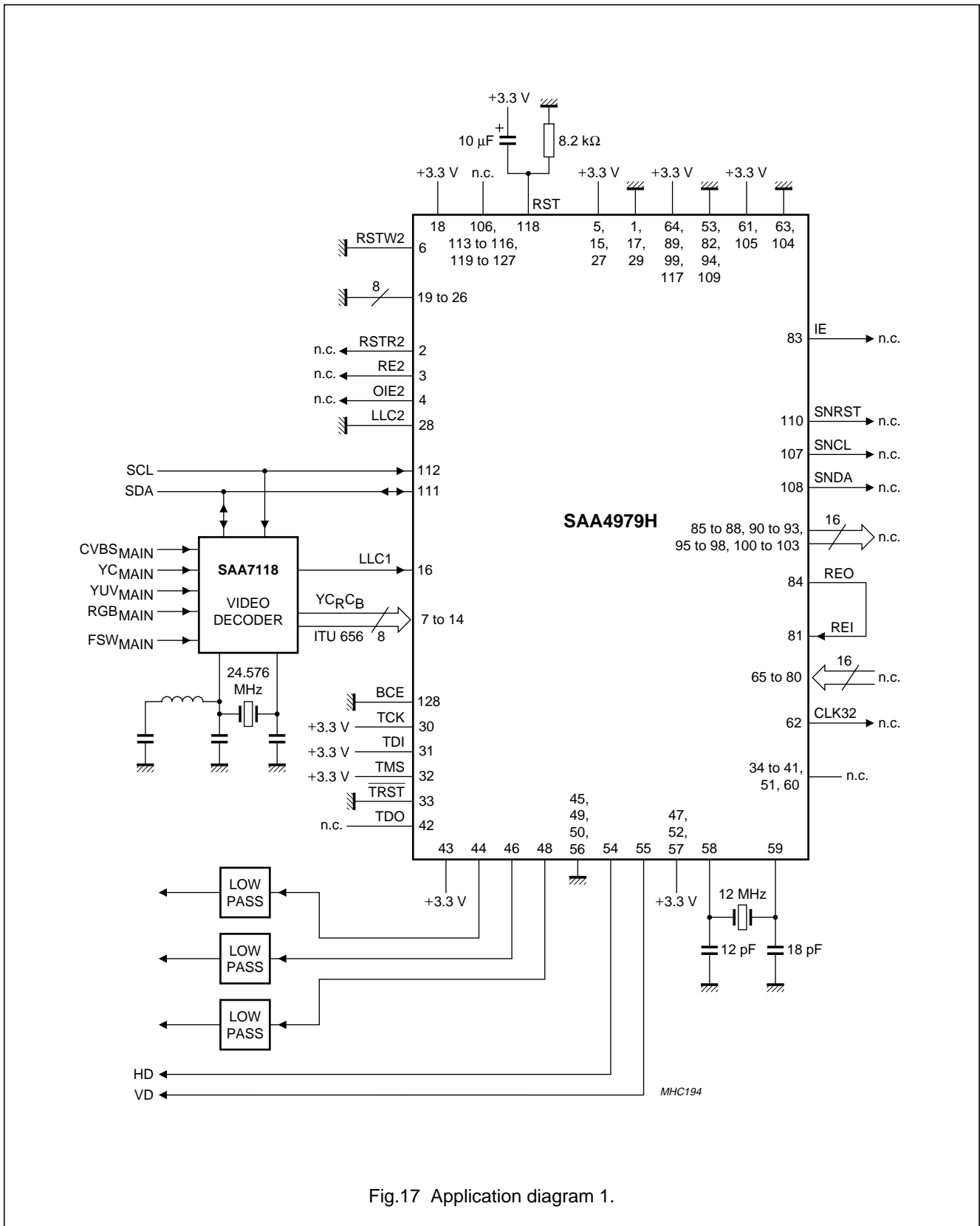

Fig.17 Application diagram 1.

Sample rate converter with embedded high quality dynamic noise reduction and expansion port

SAA4979H

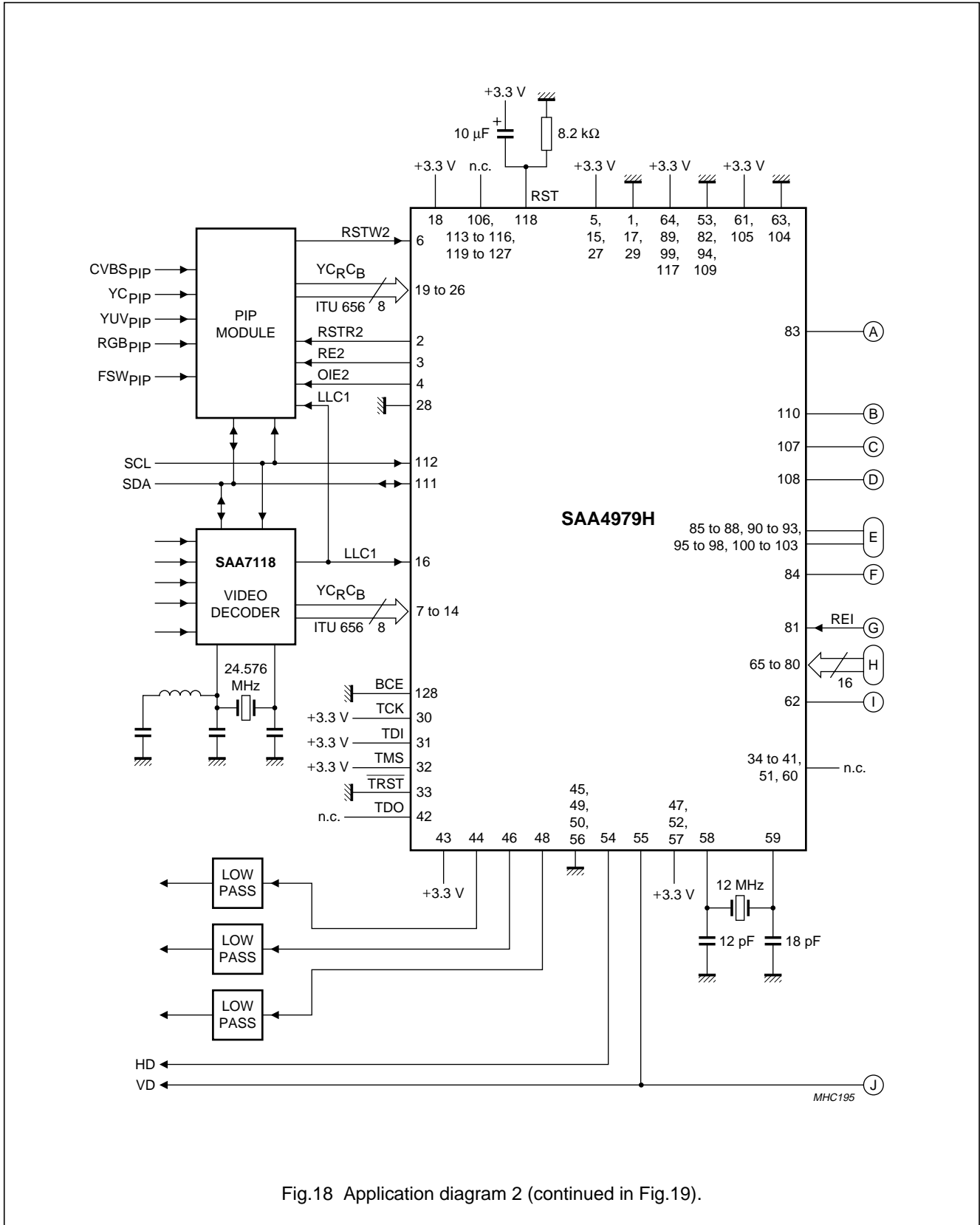

Fig.18 Application diagram 2 (continued in Fig.19).

Sample rate converter with embedded high quality dynamic noise reduction and expansion port

SAA4979H

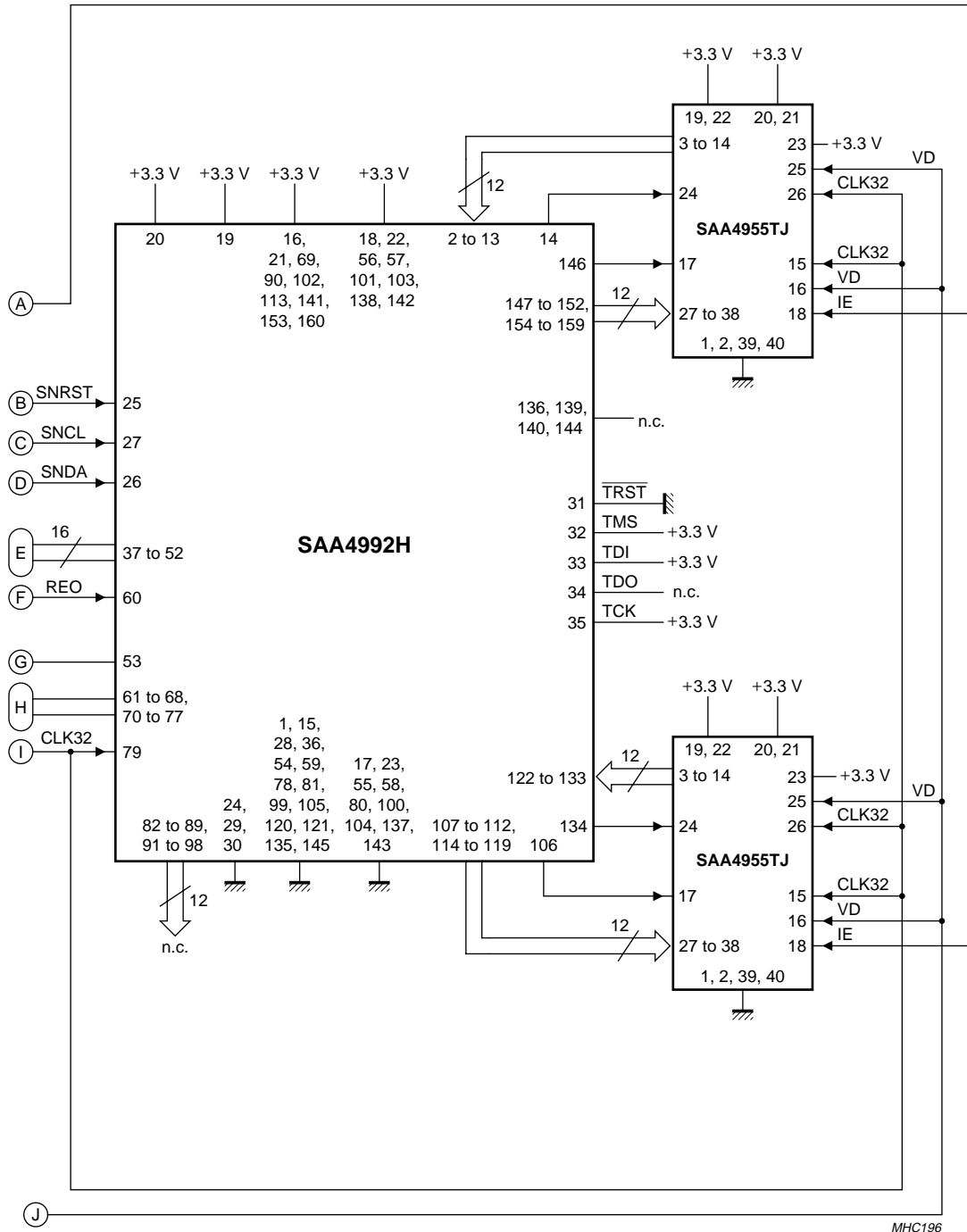
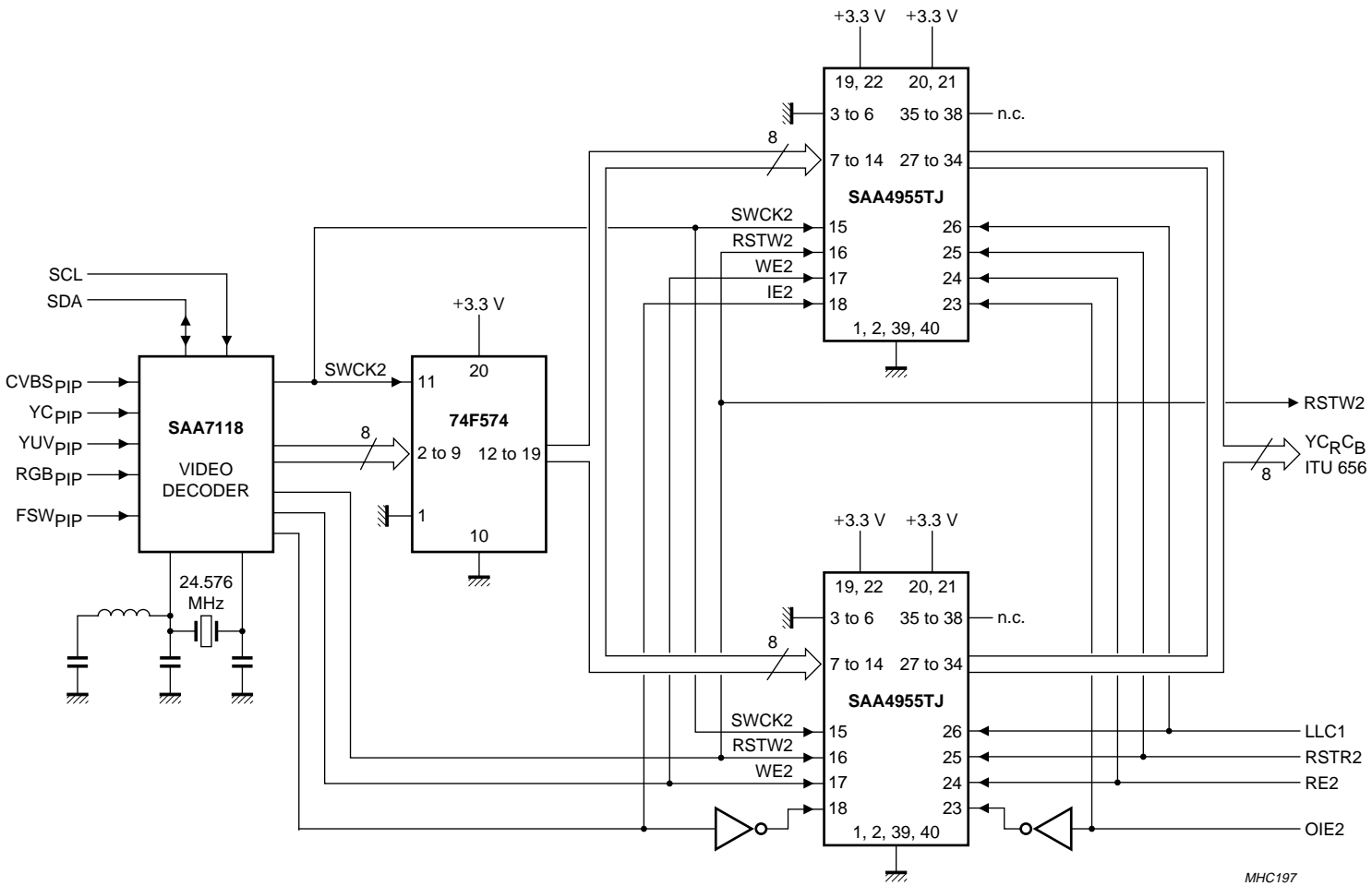

Fig.19 Application diagram 3 (continued from Fig.18).

Sample rate converter with embedded high quality dynamic noise reduction and expansion port

SAA4979H



MHC197

Fig.20 PIP module.

Sample rate converter with embedded high quality dynamic noise reduction and expansion port

SAA4979H

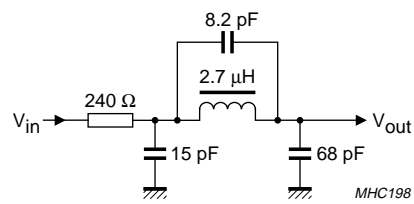

Fig.21 Low-pass filter.

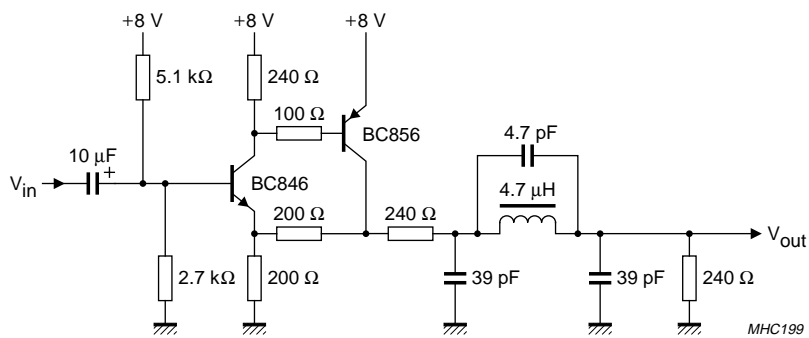

Fig.22 Low-pass filter with termination.

Sample rate converter with embedded high quality dynamic noise reduction and expansion port

SAA4979H

14 PACKAGE OUTLINE

QFP128: plastic quad flat package;

128 leads (lead length 1.6 mm); body 28 x 28 x 3.4 mm; high stand-off height

SOT320-2

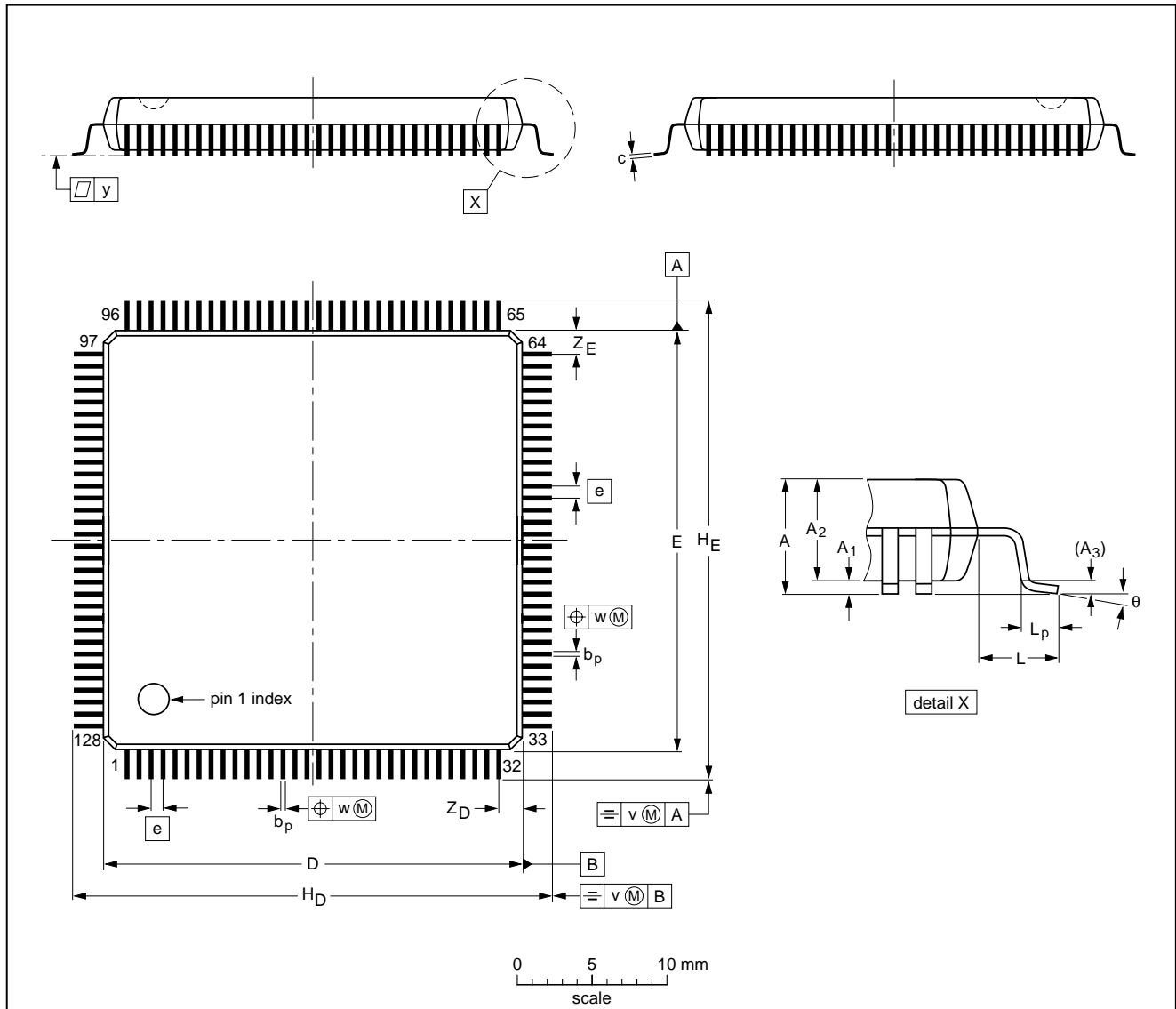

DIMENSIONS (mm are the original dimensions)

UNIT	A max.	A ₁	A ₂	A ₃	b _p	c	D ⁽¹⁾	E ⁽¹⁾	e	H _D	H _E	L	L _p	v	w	y	Z _D ⁽¹⁾	Z _E ⁽¹⁾	θ
mm	4.07	0.50 0.25	3.70 3.15	0.25	0.45 0.30	0.23 0.13	28.1 27.9	28.1 27.9	0.8	31.45 30.95	31.45 30.95	1.6	1.03 0.73	0.3	0.2	0.1	1.8 1.4	1.8 1.4	7° 0°

Note

1. Plastic or metal protrusions of 0.25 mm maximum per side are not included.

OUTLINE VERSION	REFERENCES				EUROPEAN PROJECTION	ISSUE DATE
	IEC	JEDEC	EIAJ			
SOT320-2	134E13	MS-022				99-12-27 00-01-19

Sample rate converter with embedded high quality dynamic noise reduction and expansion port

SAA4979H

15 SOLDERING

15.1 Introduction to soldering surface mount packages

This text gives a very brief insight to a complex technology. A more in-depth account of soldering ICs can be found in our *"Data Handbook IC26; Integrated Circuit Packages"* (document order number 9398 652 90011).

There is no soldering method that is ideal for all surface mount IC packages. Wave soldering can still be used for certain surface mount ICs, but it is not suitable for fine pitch SMDs. In these situations reflow soldering is recommended.

15.2 Reflow soldering

Reflow soldering requires solder paste (a suspension of fine solder particles, flux and binding agent) to be applied to the printed-circuit board by screen printing, stencilling or pressure-syringe dispensing before package placement.

Several methods exist for reflowing; for example, convection or convection/infrared heating in a conveyor type oven. Throughput times (preheating, soldering and cooling) vary between 100 and 200 seconds depending on heating method.

Typical reflow peak temperatures range from 215 to 250 °C. The top-surface temperature of the packages should preferably be kept below 220 °C for thick/large packages, and below 235 °C for small/thin packages.

15.3 Wave soldering

Conventional single wave soldering is not recommended for surface mount devices (SMDs) or printed-circuit boards with a high component density, as solder bridging and non-wetting can present major problems.

To overcome these problems the double-wave soldering method was specifically developed.

If wave soldering is used the following conditions must be observed for optimal results:

- Use a double-wave soldering method comprising a turbulent wave with high upward pressure followed by a smooth laminar wave.
- For packages with leads on two sides and a pitch (e):
 - larger than or equal to 1.27 mm, the footprint longitudinal axis is **preferred** to be parallel to the transport direction of the printed-circuit board;
 - smaller than 1.27 mm, the footprint longitudinal axis **must** be parallel to the transport direction of the printed-circuit board.

The footprint must incorporate solder thieves at the downstream end.

- For packages with leads on four sides, the footprint must be placed at a 45° angle to the transport direction of the printed-circuit board. The footprint must incorporate solder thieves downstream and at the side corners.

During placement and before soldering, the package must be fixed with a droplet of adhesive. The adhesive can be applied by screen printing, pin transfer or syringe dispensing. The package can be soldered after the adhesive is cured.

Typical dwell time is 4 seconds at 250 °C.

A mildly-activated flux will eliminate the need for removal of corrosive residues in most applications.

15.4 Manual soldering

Fix the component by first soldering two diagonally-opposite end leads. Use a low voltage (24 V or less) soldering iron applied to the flat part of the lead. Contact time must be limited to 10 seconds at up to 300 °C.

When using a dedicated tool, all other leads can be soldered in one operation within 2 to 5 seconds between 270 and 320 °C.

Sample rate converter with embedded high quality dynamic noise reduction and expansion port

SAA4979H

15.5 Suitability of surface mount IC packages for wave and reflow soldering methods

PACKAGE ⁽¹⁾	SOLDERING METHOD	
	WAVE	REFLOW ⁽²⁾
BGA, LBGA, LFBGA, SQFP, TFBGA, VFBGA	not suitable	suitable
HBCC, HBGA, HLQFP, HSQFP, HSOP, HTQFP, HTSSOP, HVQFN, HVSON, SMS	not suitable ⁽³⁾	suitable
PLCC ⁽⁴⁾ , SO, SOJ	suitable	suitable
LQFP, QFP, TQFP	not recommended ⁽⁴⁾⁽⁵⁾	suitable
SSOP, TSSOP, VSO	not recommended ⁽⁶⁾	suitable

Notes

- For more detailed information on the BGA packages refer to the "*(LF)BGA Application Note*" (AN01026); order a copy from your Philips Semiconductors sales office.
- All surface mount (SMD) packages are moisture sensitive. Depending upon the moisture content, the maximum temperature (with respect to time) and body size of the package, there is a risk that internal or external package cracks may occur due to vaporization of the moisture in them (the so called popcorn effect). For details, refer to the Drypack information in the "*Data Handbook IC26; Integrated Circuit Packages; Section: Packing Methods*".
- These packages are not suitable for wave soldering. On versions with the heatsink on the bottom side, the solder cannot penetrate between the printed-circuit board and the heatsink. On versions with the heatsink on the top side, the solder might be deposited on the heatsink surface.
- If wave soldering is considered, then the package must be placed at a 45° angle to the solder wave direction. The package footprint must incorporate solder thieves downstream and at the side corners.
- Wave soldering is suitable for LQFP, TQFP and QFP packages with a pitch (e) larger than 0.8 mm; it is definitely not suitable for packages with a pitch (e) equal to or smaller than 0.65 mm.
- Wave soldering is suitable for SSOP and TSSOP packages with a pitch (e) equal to or larger than 0.65 mm; it is definitely not suitable for packages with a pitch (e) equal to or smaller than 0.5 mm.

Sample rate converter with embedded high quality dynamic noise reduction and expansion port

SAA4979H

16 DATA SHEET STATUS

DATA SHEET STATUS ⁽¹⁾	PRODUCT STATUS ⁽²⁾	DEFINITIONS
Objective data	Development	This data sheet contains data from the objective specification for product development. Philips Semiconductors reserves the right to change the specification in any manner without notice.
Preliminary data	Qualification	This data sheet contains data from the preliminary specification. Supplementary data will be published at a later date. Philips Semiconductors reserves the right to change the specification without notice, in order to improve the design and supply the best possible product.
Product data	Production	This data sheet contains data from the product specification. Philips Semiconductors reserves the right to make changes at any time in order to improve the design, manufacturing and supply. Changes will be communicated according to the Customer Product/Process Change Notification (CPCN) procedure SNW-SQ-650A.

Notes

1. Please consult the most recently issued data sheet before initiating or completing a design.
2. The product status of the device(s) described in this data sheet may have changed since this data sheet was published. The latest information is available on the Internet at URL <http://www.semiconductors.philips.com>.

17 DEFINITIONS

Short-form specification — The data in a short-form specification is extracted from a full data sheet with the same type number and title. For detailed information see the relevant data sheet or data handbook.

Limiting values definition — Limiting values given are in accordance with the Absolute Maximum Rating System (IEC 60134). Stress above one or more of the limiting values may cause permanent damage to the device. These are stress ratings only and operation of the device at these or at any other conditions above those given in the Characteristics sections of the specification is not implied. Exposure to limiting values for extended periods may affect device reliability.

Application information — Applications that are described herein for any of these products are for illustrative purposes only. Philips Semiconductors make no representation or warranty that such applications will be suitable for the specified use without further testing or modification.

18 DISCLAIMERS

Life support applications — These products are not designed for use in life support appliances, devices, or systems where malfunction of these products can reasonably be expected to result in personal injury. Philips Semiconductors customers using or selling these products for use in such applications do so at their own risk and agree to fully indemnify Philips Semiconductors for any damages resulting from such application.

Right to make changes — Philips Semiconductors reserves the right to make changes, without notice, in the products, including circuits, standard cells, and/or software, described or contained herein in order to improve design and/or performance. Philips Semiconductors assumes no responsibility or liability for the use of any of these products, conveys no licence or title under any patent, copyright, or mask work right to these products, and makes no representations or warranties that these products are free from patent, copyright, or mask work right infringement, unless otherwise specified.

**Sample rate converter with embedded high quality
dynamic noise reduction and expansion port**

SAA4979H**19 PURCHASE OF PHILIPS I²C COMPONENTS**

Purchase of Philips I²C components conveys a license under the Philips' I²C patent to use the components in the I²C system provided the system conforms to the I²C specification defined by Philips. This specification can be ordered using the code 9398 393 40011.

Philips Semiconductors – a worldwide company

Contact information

For additional information please visit <http://www.semiconductors.philips.com>. Fax: +31 40 27 24825

For sales offices addresses send e-mail to: sales.addresses@www.semiconductors.philips.com.

© Koninklijke Philips Electronics N.V. 2002

SCA74

All rights are reserved. Reproduction in whole or in part is prohibited without the prior written consent of the copyright owner.

The information presented in this document does not form part of any quotation or contract, is believed to be accurate and reliable and may be changed without notice. No liability will be accepted by the publisher for any consequence of its use. Publication thereof does not convey nor imply any license under patent- or other industrial or intellectual property rights.

Printed in The Netherlands

753504/01/pp52

Date of release: 2002 May 28

Document order number: 9397 750 09561

Let's make things better.

**Philips
Semiconductors**



PHILIPS